

Premier EX8

COMBINED FIRE & EXTINGUISHING CONTROL PANEL
COMPLIES WITH BS EN 12094 PART 1 AND EN54 PARTS 2 & 4

Instruction Manual:

INDEX

INDEX	3
Introduction.....	4
Indications & Controls.....	5
Indications.....	5
Controls.....	7
PANEL OPERATION.....	8
Normal Operation.....	8
Fire Alarm Condition (Peripheral Zones)	8
What to do in the event of a fire.....	8
Resetting from an alarm condition.....	8
First Stage Alarm.....	9
Second Stage Alarm.....	9
Hold / Abort a Second Stage Alarm.....	9
Manual Mode.....	9
Reset.....	10
Faults.....	10
USING THE MONITORED REMOTE INPUTS	10
Manual Release Input.....	10
Gas Fired Input.....	10
Emergency Hold Input.....	11
Emergency Abort Input.....	11
Auto/Manual Input.....	11
Pressure Switch Input.....	11
Bottle Scales Input.....	12
USING THE REMOTE CONTROL INPUTS.....	12
MOUNTING THE FIRE ALARM PANEL	13
PLANNING CABLE ENTRY.....	13
FIXING THE BACK BOX TO THE WALL	13
Mains & Battery.....	14
Connecting the mains.....	14
Connecting the batteries.....	14
Charger Short Circuit Protection.....	14
Detectors & sounders.....	15
Wiring the detectors.....	15
Wiring the sounders.....	15
Other Connections.....	16
Field Monitoring Inputs.....	16
Remote Control Inputs.....	16
1 st stage & 2 nd stage Fire Relays.....	17
Fault Relay.....	17
Bottle Output.....	17
Remote Status Outputs.....	17
External Equipment Relay.....	17
Configuring the panel.....	18
Repeater Setup.....	19
Repeater connection.....	19
Disablement.....	20
To Programme an Input or Output as Disabled.....	20
Test Mode.....	21
To Programme Zone In Test.....	21
To Programme an Output In Test.....	21
Fault display & fault-finding.....	22
Fault Finding.....	22
Power Supply faults (Battery Fault/Charger Fault/Low Battery).....	22
Zone Fault.....	23
Monitored Input Faults.....	23
Sounder Circuit Fault.....	23
Earth Fault.....	24
System Fault.....	24
Repeater fault.....	24
Remote Fault.....	24
Battery Calculation.....	25
Sample Calculation.....	25
Specifications.....	26
Electrical Specifications.....	27
Enclosure Specifications.....	27
Fuse Ratings.....	27
Log Book.....	28
MAINTENANCE WORK.....	28
FALSE ALARMS.....	29
ALL OTHER EVENTS.....	30
Factory Test Record.....	31

Introduction

The Premier EX 8 is a combined 2 zone , 1 area extinguishing panel, and 4 zone conventional fire alarm panel.

The Extinguishing section is designed to BSEN12094-1:2003.

The fire alarm section is designed to EN54-2 & 4.

This design allows the same panel to protect an extinguishing area, and also monitor the rest of the site for a fire.

The panel has an integral Manual Release call point fitted to the front of the panel.

The panel has monitored inputs for field connections, such as manual release, emergency hold, etc.

The panel has relay outputs for first & second stage alarms, fault & gas fired.

The panel has remote inputs for Stop/Start Sounders, Silence & Reset, to allow the panel to be controlled remotely.

The panel has Open collector repeat outputs for most panel status indications (eg 1st stage alarm, 2nd stage alarm, Automatic mode, Manual mode etc)

The panel has a connection for a serial repeater unit (4 wire)

Indications & Controls

Indications

Here is the fascia for the Premier EX8 panel.

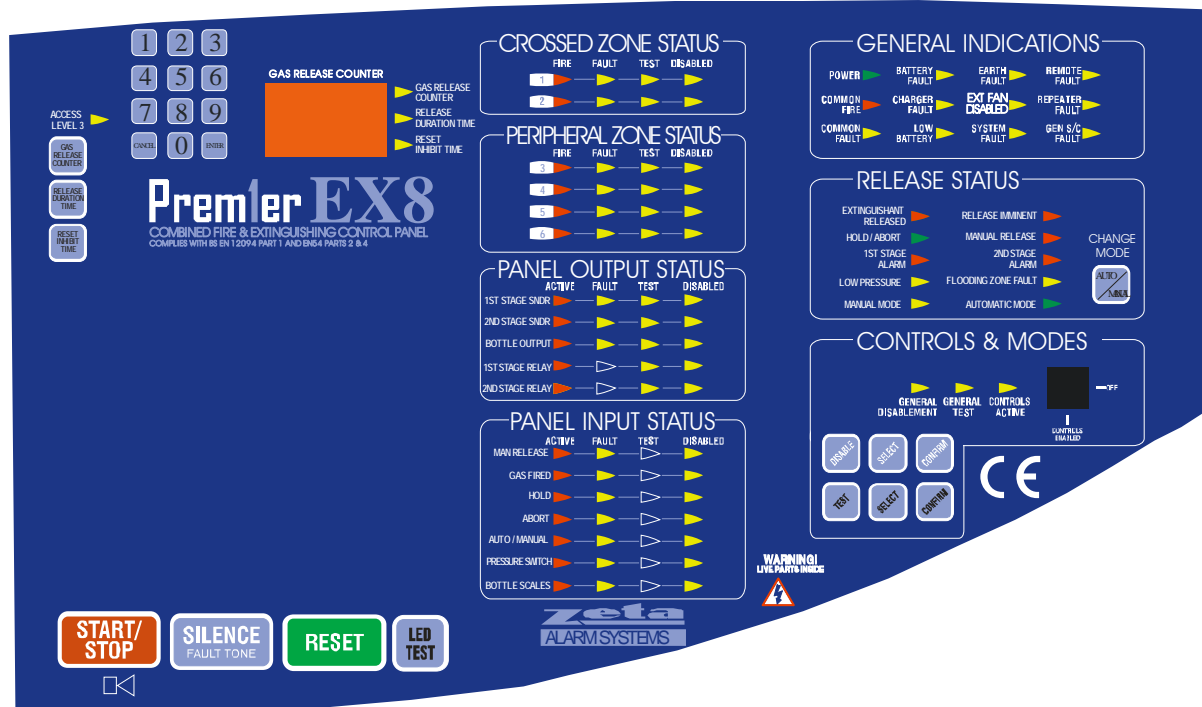

Each function has its own indication LED. There are Alarm (Active), Fault, Test & Disablement LEDs for most panel inputs & outputs. Some of these indications are not applicable for certain functions (EG a fault on the 1st or 2nd stage relays). In such cases, the LEDs are not present on the matrix (See white outlines above)

For most functions, more than one LED will light (eg zone 1 fire & COMMON ALARM)

The second stage sounder is pulsed, and it's sounder active LED will also pulse in time with the actual sounder output.

The panel also has a 3 digit 7 segment display. This is used to display the countdown timers during a second stage alarm, and also to edit the counters during set-up.

The Premier EX8 has the following LED indicators:-

LED	COLOUR	FUNCTION / MEANING
POWER	GREEN	The panel is supplied with power, either battery, mains or both
COMMON FIRE	RED	There is an alarm on the system. Check which zone caused the alarm
COMMON FAULT	YELLOW	There is a fault on the system. Another LED(s) will be lit to indicate the specific fault
BATTERY FAULT	YELLOW	There is a problem with the batteries. Rectify or replace.
CHARGER FAULT	YELLOW	The panel is not charging the batteries (usually mains fail or low mains)
LOW BATTERY	YELLOW	The batteries are below their final voltage & should be replaced
EARTH FAULT	YELLOW	Problem in system wiring. At least one cable is shorting to earth.
EXT.FAN DISABLE	YELLOW	The external equipment relay has been disabled
SYSTEM FAULT	YELLOW	The CPU has crashed, (Or CPU reset has been pressed & held)
REMOTE FAULT	YELLOW	The panel has received a fault input from external equipment
REPEATER FAULT	YELLOW	The panel has lost communication with the repeater panel
GEN S/C FAULT	YELLOW	Indicated that a line fault is caused by a short circuit
EXTINGUISHANT RELEASED	RED	The bottle output has been activated & the gas released
RELEASE IMMINENT	RED	The panel has started the release timer and will activate bottle imminently
HOLD/ABORT	GREEN	An emergency hold OR emergency abort input has been activated.
MANUAL RELEASE	RED	A manual release call point has been activated
1 st STAGE ALARM	RED	One of the crossed zones is in alarm
2 nd STAGE ALARM	RED	Both of the crossed zones are in alarm
LOW PRESSURE	YELLOW	A drop in bottle pressure has been detected
FLOODING ZONE FAULT	YELLOW	There is a fault relating to the flooding zone 1
MANUAL MODE	YELLOW	The panel is in manual only mode (ie will not be triggered by detectors)
AUTOMATIC MODE	GREEN	The panel is in automatic or manual mode
GENERAL DISABLEMENT	YELLOW	Lights when any section of the system is disabled
GENERAL TEST	YELLOW	Lights when any section of the panel is in test mode
CONTROLS ACTIVE	YELLOW	Lights when controls enabled keyswitch is on
ZONE 1 FIRE	RED	Lights when one of the detection zones is in alarm
ZONE 1 FAULT	YELLOW	Lights when one of the detection zones has a fault
ZONE 1 TEST	YELLOW	Lights when one of the detection zones is in test mode
ZONE 1 DISABLED	YELLOW	Lights when one of the detection zones is in disablement mode
1 st STAGE SNDR ACTIVE	RED	Lights when the first stage sounder is on
1 st STAGE SNDR FAULT	YELLOW	Lights when the first stage sounder has a wiring fault
1 st STAGE SNDR TEST	YELLOW	Lights when the first stage sounder is in test mode
1 st STAGE SNDR DISABLED	YELLOW	Lights when the first stage sounder is disabled
2 nd STAGE SNDR ACTIVE	RED	Lights when the second stage sounder is on
2 nd STAGE SNDR FAULT	YELLOW	Lights when the second stage sounder has a wiring fault
2 nd STAGE SNDR TEST	YELLOW	Lights when the second stage sounder is in test mode
2 nd STAGE SNDR DISABLED	YELLOW	Lights when the second stage sounder is disabled
BOTTLE OUTPUT ACTIVE	RED	Lights when the bottle output is on
BOTTLE OUTPUT FAULT	YELLOW	Lights when the bottle output has a wiring fault
BOTTLE OUTPUT TEST	YELLOW	Lights when the bottle output is in test mode
BOTTLE OUTPUT DISABLED	YELLOW	Lights when the bottle output is disabled
1 st STAGE RELAY ACTIVE	RED	Lights when the first stage relay is on
1 st STAGE RELAY TEST	YELLOW	Lights when the first stage relay is in test mode
1 st STAGE RELAY DISABLED	YELLOW	Lights when the first stage relay is disabled
2 nd STAGE RELAY ACTIVE	RED	Lights when the second stage relay is on
2 nd STAGE RELAY TEST	YELLOW	Lights when the second stage relay is in test mode
2 nd STAGE RELAY DISABLED	YELLOW	Lights when the second stage relay is disabled
MANL RELEASE INPUT ACTIVE	RED	A manual release call point connected to the remote input has been activated
MAN RELEASE INPUT FAULT	YELLOW	Fault in wiring to Manual release call point
MAN RELEASE INPUT DISABLED	YELLOW	Manual release remote input has been disabled
GAS FRED INPUT ACTIVE	RED	The panel has received a signal from the cylinder to say the gas has been released.
GAS FRED INPUT FAULT	YELLOW	There is a wiring fault to the bottle's sensor
GAS FRED INPUT DISABLED	YELLOW	The Gas fired remote input has been disabled.
EMERG. HOLD INPUT ACTIVE	RED	The emergency hold input has been activated
EMERG. HOLD INPUT FAULT	YELLOW	Fault in wiring to Emergency hold switch
EMERG. HOLD INPUT DISABLED	YELLOW	The emergency hold input has been disabled
EMERG. ABORT INPUT ACTIVE	RED	The emergency abort input has been activated
EMERG. ABORT INPUT FAULT	YELLOW	Fault in wiring to Emergency abort switch
EMERG. ABORT INPUT DISABLED	YELLOW	The emergency abort input has been disabled
AUTOMANUAL INPUT ACTIVE	RED	The panel has been set to manual mode by a remote input
AUTOMANUAL INPUT FAULT	YELLOW	Fault in wiring to Auto / Manual switch
AUTOMANUAL INPUT DISABLED	YELLOW	The Auto / Manual remote input has been disabled.
PRESS. SWITCH INPUT ACTIVE	RED	The bottle's pressure switch output has been activated
PRESS. SWITCH INPUT FAULT	YELLOW	Fault in wiring to bottle's pressure switch
PRESS. SWITCH INPUT DISABLED	YELLOW	The pressure switch input has been disabled
BOTTLE SCALES INPUT ACTIVE	RED	The bottle's scales switch has been activated
BOTTLE SCALES INPUT FAULT	YELLOW	Fault in wiring to bottle's scales switch
BOTTLE SCALES INPUT DISABLED	YELLOW	The bottle's scales input has been disabled
ACCESS LEVEL 3	YELLOW	Access level 3 selected
GAS RELEASE COUNTER	YELLOW	Gas release counter is being displayed on 3 digit display
RELEASE DURATION TIME	YELLOW	Release duration time is being displayed on 3 digit display
RESET INHIBIT TIME	YELLOW	Reset inhibit time is being displayed on 3 digit display

Controls

The Premier EX8 has the following controls:-

LABEL	USE
START/STOP	Used to silence the sounders in an alarm, or to manually start the FIRST STAGE sounders to evacuate building
SILENCE FAULT TONE	Used to silence the panel's internal buzzer in a fault or alarm condition.
RESET	Used to return the panel to its normal condition after an ALARM condition. (Reset will not clear faults)
LED TEST	To check that all indicator LEDs are working. Use as part of the daily / weekly fire alarm inspection.
DISABLE	Used to access Disablement mode
DISABLE – SELECT	Used to scroll to select which part of the system to disable
DISABLE – CONFIRM	Used to confirm disablement of the highlighted part of the system.
TEST	Used to access test mode
TEST – SELECT	Used to scroll to select which part of the system to test
TEST – CONFIRM	Used to confirm test mode of the highlighted part of the system.
AUTO / MANUAL	Used to toggle between automatic & manual only mode
GAS RELEASE COUNTER	Used to view or alter Gas Release Counter
RELEASE DURATION TIME	Used to view or alter Release Duration Time Counter
RESET INHIBIT TIME	Used to view or alter Reset Inhibit Time Counter
0-9	To enter access code & timer values
ENTER	To confirm new timer setting
CANCEL	To Save an edited time and exit from the timer set-up.

Note that the controls can only be used after the keyswitch has been turned to the ON position.

*****When the manual release call point on the front of the panel is operated, all panel controls will be inoperative. It's element will need to be reset before the panel can be reset*****

PANEL OPERATION

Normal Operation

With the "CONTROL" Key in the "OFF" position and under normal conditions the system will be silent and the green "POWER LED" illuminated.

The system may either be in "Automatic" or "Manual" mode of operation. This will be evident by the illumination of either the "Automatic" or "Manual" LED. In Manual Mode, the bottle output will not be activated automatically. It must be started manually by pressing a manual release call point.

Fire Alarm Condition (Peripheral Zones)

The Premier EX8 signals an alarm by the following:-

- Turn on the General Fire LED
- Turn on the Zonal Fire Indicator
- Turn on internal buzzer
- Start any sounders connected to the panel's sounder circuits
- Activate the fire relay

What to do in the event of a fire.

1. Follow the building evacuation procedure, and check that everyone has left the building safely.
2. The building fire officer or suitably trained responsible person should CAREFULLY enter the building, and locate the area of the alarm from the fire alarm panel.
3. Investigate to determine the cause of the alarm. Look for the detector in the zone in alarm that signalled the fire. The detector that signalled an alarm will have its RED ALARM LED on.
4. If a small fire is found, a suitably trained person could tackle this with a suitable fire extinguisher.
5. If a larger fire is found, leave the building immediately, and contact the fire brigade.
6. If no fire is found, make a note of the detector that signalled fire, and look for anything nearby that could be the cause of the activation, eg cooking, or use of a hot air gun etc.
7. Record findings in the fire alarm log book.

Resetting from an alarm condition

After the relevant action has been taken, the Premier EX8 fire alarm panel can be reset by the following:-

- 1 Press Stop/Start sounder button, This will silence the external sounders.
- 2 Press Silence Fault Tone button. This will silence the panel's internal buzzer.
- 3 Press the Reset button. This will return the panel to it's normal condition.

If the panel goes straight back into alarm, then the cause of the alarm has not been cleared. This could be a detector still exposed to smoke, or a call point still in the active position. Press Buttons 1 & 2 on the panel, then investigate for a call point, or detector that still has it's RED ALARM LED on. Reset the call point, or clear the smoke. If the problem persists, contact an engineer.

First Stage Alarm

On detection of a "FIRE" in either Zone 1 or Zone 2, the zone fire LED will be illuminated and the internal buzzer will be on. The first stage LED and first stage sounder will be on. The first stage relay output will be active.

To silence the sounder, turn the keyswitch to ON position, and press silence button. The panel's internal tone and fire LEDs will remain active until the cause of the alarm has been removed, and the panel has been reset

A first stage alarm can be created manually by turning the keyswitch to the on position and pressing the 1st STAGE ALARM button.

A first stage alarm can be silenced & reset when the panel is in automatic or manual mode.

Second Stage Alarm

As soon as a "FIRE" is detected in the second Zone, the second stage alarm is initiated. The second stage sounder will be pulsed on for 1 second, then off for 1 second. This will be repeated as the timer counts down. The two-zone alarm LEDs will be illuminated as well as first stage alarm, second stage alarm and Gas Imminent LEDs. The second stage cannot be silenced and after a delay period, (user programmable) the extinguishing output will be initiated releasing the extinguishing agent, and the second stage sounder will now be on constantly. This will be followed by the "GAS FIRED" indication, indicating that the extinguishing agent has been released.

Once the second stage alarm has been initiated, it is advisable to evacuate and Seal the protected area prior to the release of the extinguishing agent.

Operation of the "Manual Release" call point will initiate the second stage alarm. Lift the flap and push the operating element.

A second stage alarm can only be silenced & reset when the panel is in manual mode.

Hold / Abort a Second Stage Alarm

If the hold **or abort** input is activated during a second stage alarm, the second stage sounder will now pulse on for 0.5 seconds, then be off for 2 seconds, and will repeat. If a hold input is used, the panel will revert to its programmed countdown when the input is released. If an abort input is used, the panel will abort the gas release, and the panel will need to be reset.

Manual Mode

In this mode operation, Zone Fire and Fault alarms are still in operation, and first & second stage sounders will operate, but the bottle output to the extinguishing agent will not operate.

Reset

To reset panel from an alarm condition, press Silence then Reset.

The panel can NOT be reset from a fault condition. All faults are non latching, so when a fault clears from the panel it will be automatically cleared from the display. If the panel enters the second stage alarm (while in automatic mode), the panel cannot be reset.

Faults

The relevant LED will illuminate and the internal tone will sound. Pressing the "Silence" button, with the control key "ON", will silence the tone. If there are any faults, call an Engineer.

USING THE MONITORED REMOTE INPUTS

The Premier EX8 has the following remote inputs:-

- Manual Release
- Gas Fired
- Hold
- Abort
- Auto/Manual
- Pressure Switch
- Bottle Scales

They Operate as follows:-

Manual Release Input

The Premier EX has a Manual release call point fitted to the front of the panel. It also has a monitored input which allows extra manual release call points to be fitted to the system. The line needs a 2k2 end of line resistor, and the manual release call point must place a 470R resistor across the line to trigger it.

There is a RED "ACTIVE" LED which lights when the input has been operated, and a yellow fault LED that lights in the event of an O/C or S/C line fault.

When a Manual release is initiated, the panel will light its Manual Release LED.

Disabling the Manual release input also disables the built in manual release call point.

Gas Fired Input

This input connects to the gas bottle's signal that the gas has been released. The line needs a 2k2 end of line resistor, and a 470R resistor across the line to trigger it

In the event of a second stage alarm, or manual release, the panel will operate its bottle output, and the bottle will send a gas fired signal back into the panel. On receiving this signal, the panel will light its EXTINGUISHANT RELEASED LED, and turn on its Gas fired relay.

There is a RED "ACTIVE" LED which lights when the input has been operated, and a yellow fault LED that lights in the event of an O/C or S/C line fault.

If this input is disabled, the panel can still release its gas, but the gas fired relay will not operate.

Emergency Hold Input

This input connects to an Emergency Hold Switch or call point. The line needs a 2k2 end of line resistor, and a 470R resistor across the line to trigger it.

If this input is operated during a second stage alarm, during the release count down, it will reset the counter to it's starting value, and hold it there, until the Hold device is reset. This prevents the panel from releasing the gas. When the hold device is reset, the panel resumes counting, and will release the gas at the end of the countdown.

There is a RED "ACTIVE" LED which lights when the input has been operated, and a yellow fault LED that lights in the event of an O/C or S/C line fault.

If this input is disabled, any hold devices connected to the line will not be able to stop the gas release.

Emergency Abort Input

This input connects to an Emergency Abort Switch or call point. The line needs a 2k2 end of line resistor, and a 470R resistor across the line to trigger it.

If this input is operated during a second stage alarm, during the release count down, it will freeze the counter. The counter WILL NOT restart if the abort is released. The panel needs to be reset to exit this condition.

There is a RED "ACTIVE" LED which lights when the input has been operated, and a yellow fault LED that lights in the event of an O/C or S/C line fault.

If this input is disabled, any Abort devices connected to the line will not be able to stop the gas release.

Auto/Manual Input

This input connects to an Emergency Abort Switch or call point. The line needs a 2k2 end of line resistor, and a 470R resistor across the line to trigger it.

When the panel is in automatic mode, and this input is operated the panel changes to manual mode. When the input is released, the panel reverts to Automatic Mode. If the panel is already in manual mode, this input will have no effect.

There is a RED "ACTIVE" LED which lights when the input has been operated, and a yellow fault LED that lights in the event of an O/C or S/C line fault.

If this input is disabled, the panel facia auto/manual toggle button will still work.

Pressure Switch Input

This input connects to an Emergency Abort Switch or call point. The line needs a 2k2 end of line resistor, and a 470R resistor across the line to trigger it.

This is an ancillary bottle connection. If the bottle has only a pressure switch to indicate the release of the gas, it should be connected to the GAS FIRED input. If the bottle has more than one input, connect the primary indication to GAS FIRED, and the secondary indication can be connected to the pressure switch input.

There is a RED "ACTIVE" LED which lights when the input has been operated, and a yellow fault LED that lights in the event of an O/C or S/C line fault.

Disabling this input prevents it from showing as active on the panel display.

Bottle Scales Input

This input connects to an Emergency Abort Switch or call point. The line needs a 2k2 end of line resistor, and a 470R resistor across the line to trigger it.

This is an ancillary bottle connection. If the bottle has only a bottle scales to indicate the release of the gas, it should be connected to the GAS FIRED input. If the bottle has more than one input, connect the primary indication to GAS FIRED, and the secondary indication can be connected to the bottle scales input.

There is a RED "ACTIVE " LED which lights when the input has been operated, and a yellow fault LED that lights in the event of an O/C or S/C line fault.

Disabling this input prevents it from showing as active on the panel display.

USING THE REMOTE CONTROL INPUTS

The Premier EX8 has remote control inputs for Start/Stop Sounders, Silence Buzzer, Reset and Remote fault.

They are operated by connecting the signal to 0V. The first 3 will mimic pressing the button on the front panel. The Fault input is used to receive a fault signal from external equipment (eg an add on power supply). If this input is operated it will operate the panel's fault relay.

These inputs can be connected to key controlled switches, or Output modules on an addressable fire alarm system. Remember to heed local fire fighting regulations when using remote inputs.

The remote inputs to not prevent the panel buttons from functioning.

MOUNTING THE FIRE ALARM PANEL

The Premier EX8 comes with many cable entry holes. If another entry hole is required, it is strongly recommended that the panels door be removed to avoid accidental damage. Also, the termination PCB should be removed and stored in a safe place. This would also help while fixing the back box to the wall.

PLANNING CABLE ENTRY

Fig.2 below shows the location of the cable entries to facilitate planning of wiring (home runs) to be brought to the panel.

The grommets can be easily removed by a push from inside the control panel box.

If a grommet is removed, fill the hole with a brass cable gland. If any knockout is removed, but subsequently not used, it should be covered up.

The 230V a.c. Mains cable must be fed into the enclosure via one of the cable entries at the top right corner of the back box. (Refer to "Connecting the Mains" on Page 8).

FIXING THE BACK BOX TO THE WALL

Figure 2: Plan view inside the enclosure without PCBs. Side view for surface installation.

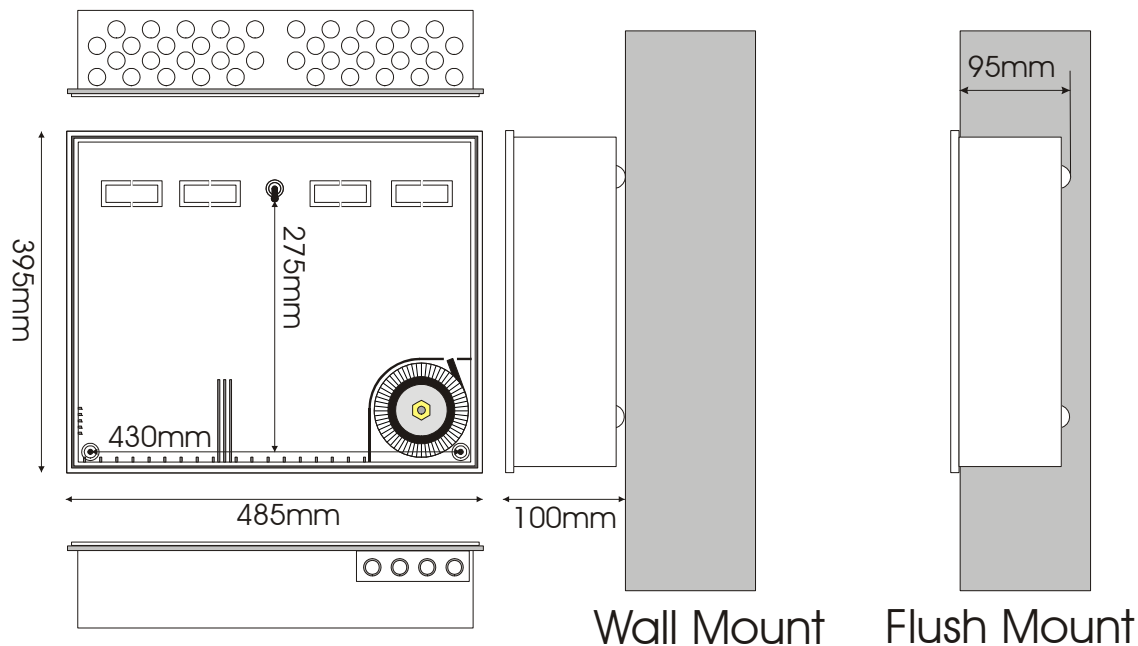

Fix the enclosure to the wall using the three mounting holes provided.

Check the build & condition of the wall to decide a suitable screw fixing.

The mounting holes are designed for No 8 roundhead or countersunk woodscrews (or similar).

Remove any debris from the enclosure.

Take care not to damage the FACP during installation.

Mains & Battery

Connecting the mains.

The Mains supply to the panel is fixed wiring, using **Fire resisting** 3-core cable (Between 1 mm² and 2.5mm²) or a suitable 3-conductor system, fed from an isolating double pole switch fused spur, fused at 3A. **IT SHOULD NOT BE CONNECTED THROUGH AN RCD.** This should be secure from unauthorised operation and be marked 'FIRE ALARM: DO NOT SWITCH OFF'. The supply must be exclusive to the Fire Panel. **MAKE SURE ANY SPARE ENTRY HOLES ARE COVERED WITH THE GROMMETS PROVIDED**

Connecting the batteries

The Premier EX8 requires 2 x 12 V sealed lead acid (SLA) batteries

The two batteries are wired in **series**.

The **+ve** of one battery is connected to the **red** battery lead.

The **-ve** of the other battery is connected to the **black** battery lead.

The **-ve** of the first battery is connected to the **+ve** of the second battery using the link wire supplied.

Although there are many sizes of suitable battery, the enclosure has been designed for 12V 7Ah or 12V 12Ah. Use the battery calculation information later in this manual to work out the required stand by battery size.

Charger Short Circuit Protection

The Premier EX8 has an intelligent charger that senses if too much current is being drawn (for instance in the case of totally discharged batteries, or the charger leads being shorted together). In such an event, the Premier EX8 4-8 zone panel will turn off the power to its charger circuit.

The panel also turns off the charger when the batteries are disconnected.

Detectors & sounders

Wiring the detectors

There are two types of detection zone on the Premier EX8 panel. The Co-occurrence (Double-Knock) zones for the extinguishing circuit uses common bases (no diode), and a 2.7k end of line resistor. Call points can NOT be connected to these zones.

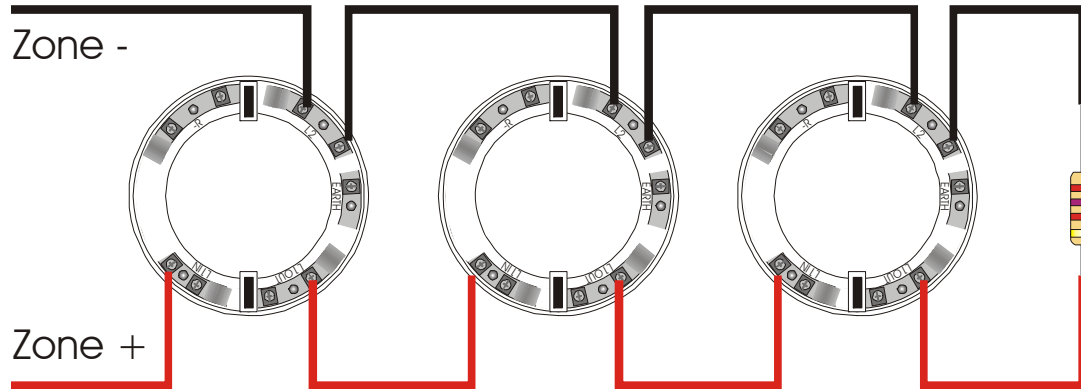

The Peripheral (fire alarm) zones use diode bases and a 100µF capacitor end of line. These zones support head removal detection without cutting power to the rest of the zone. Call points can be connected anywhere on these zones.

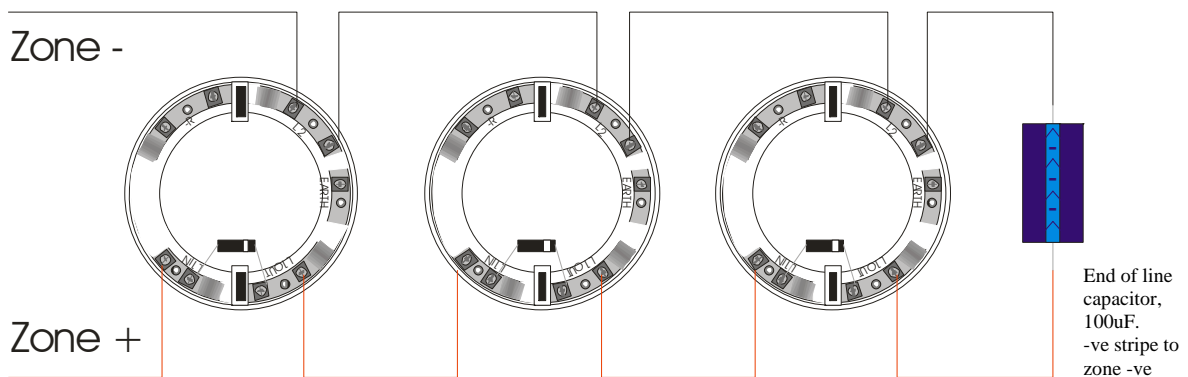

The diode (also known as a continuity diode) passes power to the downline detectors and call points, if a detector head is removed for any reason.

Wiring the sounders

The Premier EX8 has 2 first stage / fire sounder circuits, each rated at 150mA. Each sounder circuit must be fitted with a 10k end of line resistor. The EX8 also has 1 x second stage sounder circuit rated at 250mA. This also uses a 10K end of line resistor. This second stage sounder circuit is designed for an alarm device that gives a constant sound pattern (either sounder or bell) because it uses on/off sound patterns to indicate different gas release conditions.

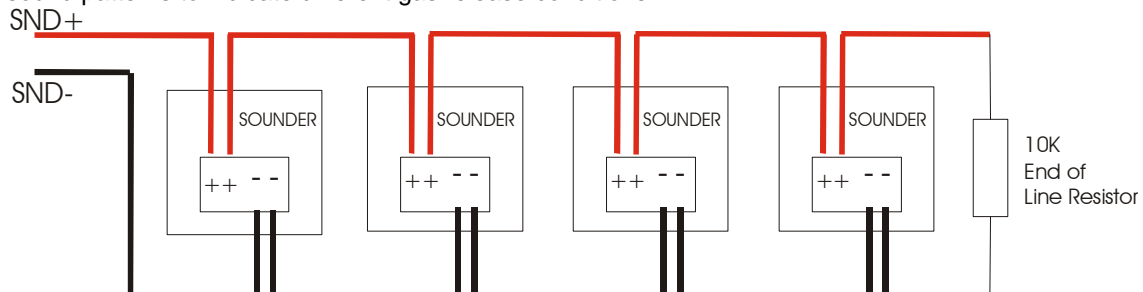

Other Connections

The Premier EX8 also has the following connections:-

Field Monitoring Inputs

- Gas Fired
- Manual Release
- Emergency Hold
- Automatic/Manual Mode
- Low pressure
- Emergency Abort
- Bottle Scales

The EX8 has inputs which are monitored for Open Circuit & short circuit. To activate the input, a load of 470 ohms must be switched between the +ve & -ve lines.

If the equipment being connected has Normally Closed & Normally Open contacts, connect the 2k7 end of line resistor & 470R triggering resistor as follows:-

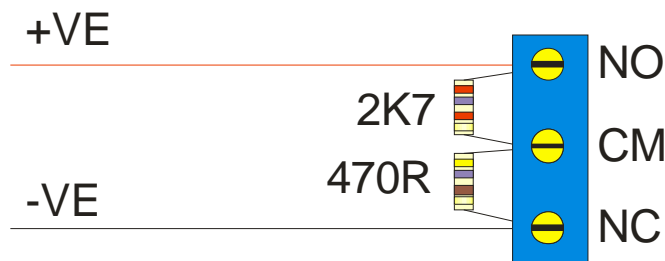

If the equipment only has normally open contacts, wire as follows:-

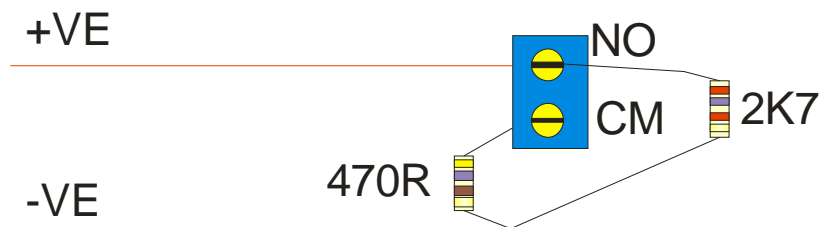

Remote Control Inputs

- Start/Stop Sounders
- Silence
- Reset
- Remote Fault

The Premier EX8 has 4 remote control inputs. They have the same function as the panel button. These are activated by switching the relevant input to 0V. EG



1st stage & 2nd stage Fire Relays

The Premier EX8 has one first stage & one second stage volt free change over relay that operates on an alarm. It is rated at 1Amp, SELV. The relay remains operated until the panel has been reset. (note: the 1st stage relay operates from an alarm from a crossed zone OR a peripheral zone)

Fault Relay

The Premier EX8 has one volt free change over relay that operates on any fault condition. The Relay is Normally energised, so that it gives a signal in the event of total power failure (Mains & Battery back-up). It is rated at 1Amp, SELV. The relay remains operated until the fault has been cleared.

Bottle Output

The Bottle Output on a Premier EX8 panel is used to drive a gas release solenoid. It is fused @ 1 Amp.

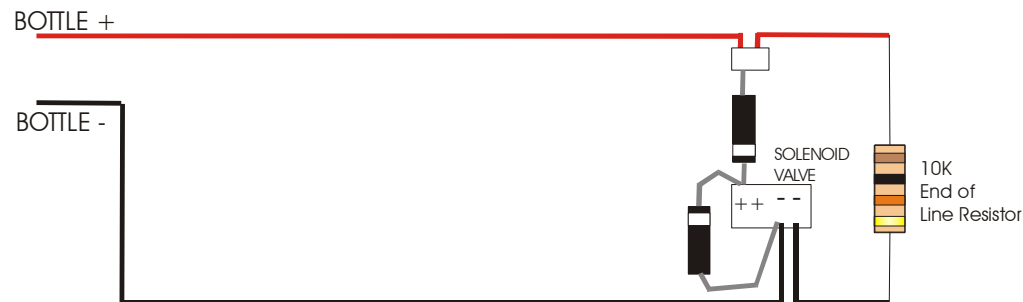

Remote Status Outputs

The panel has the following remote outputs:-

- Abort Active
- Hold Active
- Manual release operated
- Bottle operated
- First stage alarm present
- Second stage alarm present
- Automatic mode selected
- Manual mode selected
- fault

Connecting between LED STAT + and the relevant Remote output will give a 28V output when the signal is active. This can be used to drive a relay, or a remote indication LED.

External Equipment Relay

The Premier EX8 has one volt free change over relay that operates AFTER the Reset Inhibit Counter has finished. It remains active for 3 minutes, or until the reset button is pressed. It is rated at 1Amp, SELV.

Configuring the panel.

The Premier EX8 has been designed to be easy to set up. Zones 1 & 2 are configured as the double knock pair, so do not need to be configured as such.

There are 3 timers to set:

- The Gas Release Counter.
- The Release duration Timer
- The Reset Inhibit Timer

The rest of the setup is automatic.

The Gas Release Counter is the delay between the receipt of a second stage alarm, and the gas being released. It can be set from 2 to 59 seconds in 1 second increments. To set the counter press “GAS RELEASE COUNTER BUTTON”. Access Level 3 & Gas release Counter LEDs will flash. Enter the access code 5312. The 3 digit display will display the currently programmed delay (eg 30). Enter the new delay & press enter (eg 59 – enter). Press cancel to exit & save value.

FACTORY DEFAULT SETTING: 30 Seconds

The Release Duration Timer determines how long the bottle output remains active. The bottle output will then shut off because it is no longer needed. This will prevent unnecessary power drain. It can be set from 2 to 299 seconds in 1 second increments. To set the counter press “RELEASE DURATION TIME”. Access Level 3 & Release Duration Time LEDs will flash. Enter the access code 5312. The 3 digit display will display the currently programmed delay (eg 60). Enter the new delay & press enter (eg 200 – enter). Press cancel to exit & save value.

FACTORY DEFAULT SETTING: 40 Seconds

The Reset Inhibit Timer prevents the panel being reset immediately after a release. This prevents a panel from being reset, so that the system can be investigated by the responsible person to determine the cause of the release. It can be set from 2 to 299 seconds in 1 second increments. To set the counter press “RESET INHIBIT TIME”. Access Level 3 & Reset Inhibit Time LEDs will flash. Enter the access code 5312. The 3 digit display will display the currently programmed delay (eg 60). Enter the new delay & press enter (eg 200 – enter). Press cancel to exit & save value.

FACTORY DEFAULT SETTING: 60 Seconds

(NOTE that the reset inhibit time counter starts when the bottle output activated, NOT when it de-energises, so that if the reset inhibit timer is less than or equal to the release duration timer, it will not be seen as part of the usual countdown procedure.)

Repeater Setup

The Premier EX8 has a serial repeater available. The repeater has a 4 wire connection to the main panel (2 for power, 2 for data). This is usually used if there is more than one entrance to a protected area.

The repeater has a manual release call point built in.

It also has controls to toggle the main panel between automatic & manual mode. (The access controls keyswitch must be set to controls enabled first before pressing the Auto / Manual changeover button to toggle the state)

It has LED indications for :-

- Power
- Supply Fault (main panel)
- Automatic Mode
- Manual Mode
- Bottle Disabled
- Hold active
- Abort Active
- Manual Release Activated
- Fire
- Gas Imminent (second stage activated)
- Gas Released

To monitor the Repeater, fit the jumper link to the main panel CPU card.

Repeater connection

Wire the repeater panel as shown:-

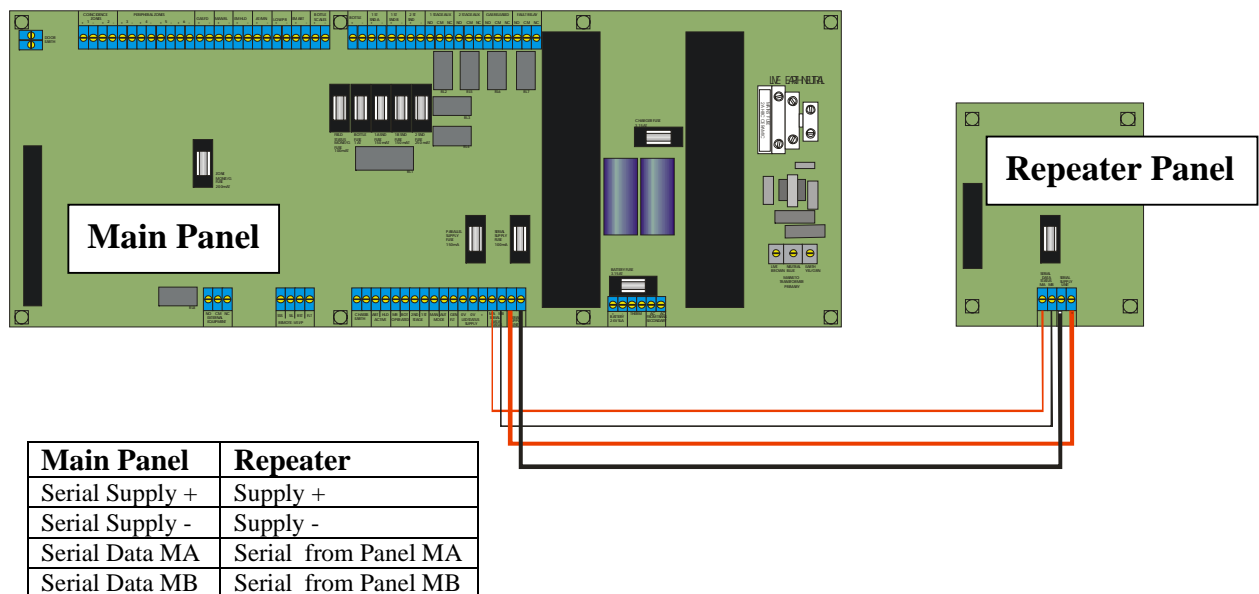

Disablement

The Premier EX8 zone allows any of the following to be disabled to aid commissioning and assist routine maintenance work:-

- Crossed zones
- Peripheral Zones
- First stage sounders
- Second stage sounders & Bottle output (Disabled together)
- First Stage Relay
- Second Stage Relay
- External Equipment Relay
- Panel's Monitored Inputs for field devices

When an input is disabled, the panel will not respond to any fault or fire signals it receives from that input. When an output is disabled, the panel will not activate that output.

This might be used if the system requires routine maintenance, and the customer needs the system to continue running, but doesn't want spurious false alarms or fault signals.

The panel will respond in the usual manner to any events in any non-disabled inputs.

To Programme an Input or Output as Disabled

Any number of inputs or outputs can be disabled, but it is good practice to only disable the minimum requirement at a time.

Insert and turn control key to enabled position;

Press DISABLE button and the GENERAL DISABLEMENT LED will come on (flashing fast, 4 flashes then off, repeated);

Press SELECT button. The GENERAL DISABLEMENT LED will light steady, and the Crossed Zone 1 Disabled LED will flash 4 quick flashes & off. The panel is now in SELECT DISABLEMENT MODE.

The select button is used to highlight (flash) the section that needs to be disabled. Press select button until the correct LED is flashing, then press confirm. The LED will now flash 4 quick flashes & on, to indicate that this section is disabled.

If more than one section needs to be disabled, then press SELECT button again until the required zone is selected. (The previously disabled section will now have its disabled LED lit steady.)

If the panel needs to be taken out of SELECT DISABLEMENT MODE (eg to silence a fault on another part of the system), turn the keyswitch off, then back on again.

Once all the work has been done the zones need to be enabled again. If the panel is not in SELECT DISABLEMENT MODE, turn the keyswitch to controls enabled, press DISABLE button.

Press the scroll button until the disabled section has been selected. Press CONFIRM button to re-enable. Scroll to any other disabled section and enable in the same way. When all sections are enabled again, turn the keyswitch to off to return the system to normal.

Test Mode

To aid commissioning and assist routine maintenance check, a non-latching 'one man test' facility is available.

When a detector or manual call point is triggered on any zone in Test, the Alarm sounders operate for approximately seven seconds on and seven seconds off. This cycle continues until the cause of the Alarm is removed (either by the test smoke clearing from the detector or the manual call point being reset), at which point, the detector circuit also automatically resets.

Should an Alarm occur on a zone that is not programmed to test, the Alarm will be processed in the normal way. The testing of the zone in test will temporarily be suspended until the Alarm(s) from the other zones are reset. At this point, zone retesting may resume.

The Premier EX8 can place the following circuits into test mode:-

- Crossed zones 1 & 2
- Peripheral zones 3 to 6
- First Stage sounders
- Second stage sounders
- First stage relay
- Second stage relay

To Programme Zone In Test

NOTE: Only **one zone** can be programmed in test at any one time.

1. Insert and turn control key to enabled position;
2. Press TEST button. The General test LED is on (flashing fast);
3. Enter Engineer Code 2435 and then the General Test LED is on (3 flashes then off – repeated);
4. Press Select button and Zone one TEST LED will flash in synchronisation with the General test LED;
5. Press Select button to select the desired Zone for test. Press confirm. The zone LED & General test LED will now flash slowly. This Zone is now in test mode.
6. Any alarm in this zone will activate the first stage sounders & relay for aprox 3 seconds, then reset them.
7. Once testing of that zone is completed, press scroll button to move to another Zone or turn the control key switch to off position to exit test mode.

To Programme an Output In Test

NOTE: Only **one Output** can be programmed in test at any one time.

1. Repeat steps 1 to 4 above.
2. Press SELECT button to choose the output to test.
3. Press confirm Button. The output (either sounder or relay) turns on.
4. Press confirm button again to turn the output off.
5. Repeat for all outputs to be tested.

Fault display & fault-finding

The Premier EX8 zone panels monitor for the following faults:-

- Low or failed mains (Including fuses)
- Low or failed battery (Including fuse)
- Detection Zone open or short circuit wiring fault
- Detection Zone detector removed.
- Sounder circuit open or short circuit wiring fault
- Bottle open or short circuit wiring fault
- Monitored input circuit open or short circuit wiring fault
- Earth Fault
- System fault
- Repeater Fault
- Remote fault

Most of these faults will need to be checked by an engineer, but the system can be checked for a removed detector by the responsible person.

All faults in the Premier EX8 are NON-LATCHING. IE they can not be reset with the reset button. They will clear automatically when the fault has been fixed. The exception is a SYSTEM FAULT, which means that the processor may have crashed, and may or may not have restarted correctly.

Fault Finding

Power Supply faults (Battery Fault/Charger Fault/Low Battery)

A power supply fault is indicative of one or more of the following faults: -

Loss of Mains power

- Check that 230V AC is present at the mains terminal block
- Check mains fuse
- Check that there is 30-34V coming from the transformer secondary
- Check charger fuse FS9.

Loss of Battery power

- Check that 2 X 12V batteries are fitted in series to give 24V backup
- Check battery fuse FS8.
- Check that battery connections are secure.
- Check that the batteries are not over 5 years old
- Check that the 2 batteries have a combined voltage of over 21V DC (The panel will refuse to charge batteries with a voltage less than 21V because they can't be guaranteed to hold a charge)

The panel will also indicate a charger fault if the serial supply fuse (FS7) or parallel supply fuse (FS6) have blown.

Zone Fault

A Zone Fault is indicative of one or more of the following faults:-

Open Circuit fault.

- Check that the correct end of line has been fitted (2k2 resistor for crossed zones, 100uF 40V capacitor for peripheral zones)
- Check Zone Monitoring Fuse FS1
- Check that there are no breaks in the cable, and that all screw connections are secure.
- Check that no detectors have been removed from the circuit.
- Check that all detectors are correctly fitted to their bases.
- As a cable check, remove zone wire from panel. Temporarily join the + & - cables at the end of line & Check for continuity. (If a break is found, splitting the line in half & fitting EOL will help determine which section of cable has the fault)
- As a panel check, remove cable & fit EOL at the panel. If the fault clears, the panel is working correctly.
- If a panel does not report a fault when an detector is removed, check with your supplier if the detector is compatible with the Premier EX8.

Short Circuit Fault (Gen S/C LED will be lit)

- Check that the correct end of line has been fitted (see above), and check that it has not been fitted backwards. The capacitor should be fitted with the -ve arrow stripe pointing to -ve
- Check that no equipment, other than detectors or call points has been fitted to the zone.
- Check for shorts to the cable screen.
- Check that none of the heads have become damaged (remove one at a time).
- As a panel check, remove cable & fit EOL at the panel. If the fault clears, the panel is working correctly.

Monitored Input Faults

As above, except EOL is 2k2, and Fuse is FS2

Sounder Circuit Fault

A Sounder Fault is indicative of one or more of the following faults:-

Sounder Open Circuit fault.

- Check that the correct end of line resistor (10K) has been fitted to both circuits
- Check that sounder fuses FS4 & 5 are intact.
- Check that there are no breaks in the cable, and that all screw connections are secure.
- As a panel check, remove both circuits cable & fit both EOLs at the panel. If the fault clears, the panel is working correctly.

Short Circuit Fault (Gen S/C LED will be lit)

- Check that the correct end of line has been fitted to both circuits (10k resistor)
- Check that ALL sounders, Bells etc are POLARISED, and are fitted the correct way round. (see diagram after list)
- Check for shorts to the cable screen.
- As a panel check, remove cable & fit EOL at the panel. If the fault clears, the panel is working correctly.

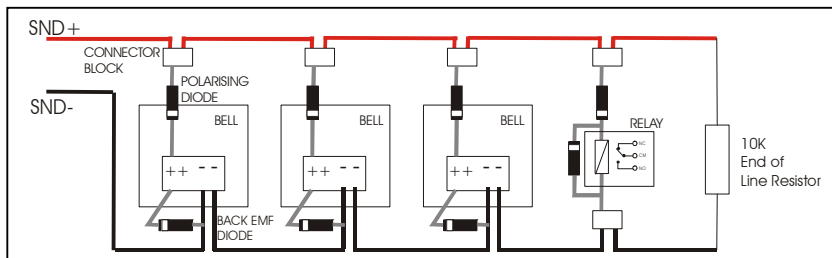

Note: If non-polarised alarm devices (eg some types of old mechanical bell, or a relay) are used, then a diode will have to be placed in line with the device to enable fault monitoring. They may also need a back EMF protection diode. (symptoms: Chattering sounder relays that don't turn off).

Earth Fault

An EARTH fault indicates that something is shorting to earth (usually through the cable screen). Disconnect the earth screens one at a time to determine the problem line.

(Note: connecting other equipment , eg an oscilloscope or PC, to the panel can give an earth fault)

The voltage between battery –Ve and earth should be 14-16 volts. If it is not, the voltage should indicate what is shorting to earth.

System Fault

A system fault is an abnormal microprocessor running condition due to various unexpected phenomena.

This will result in the panel attempting to correct itself. Should this fault occur, the System Fault LED, General Fault LED, General Fault relay and fault internal buzzer will be constantly active until the control keyswitch is turned from off position to control enable position. This should cause this fault condition to reset. If not, consult your supplier.

Repeater fault

The panel can no longer communicate with the repeater (check that the cables are intact, and that the fuse in the repeater, and the panel's serial supply line are intact. If the system does not have a repeater, then the monitoring link has been incorrectly fitted.

Remote Fault

The panel has received a signal on it's remote fault input. Check any items connected to this input.

Battery Calculation

Here is the current consumption of the Premier EX8 panels in various conditions:-

Control Panel Model	Mains Fail, buzzer sounding	Mains Fail, buzzer silenced	Mains fail, panel in alarm	Mains fail, panel in 2 nd stage alarm
Premier EX8 Panel	160mA	140mA	200mA	350mA(420pk)

Sample Calculation

A Premier EX8 4 zone panel has the following items connected:-

Zone 1: 8 x Optical detector

Zone 2: 7 x Optical detector

Zone 3: 3 x MCP, 9 x Optical, 1 x heat detector

Zone 4: 1 x MCP, 10 x Optical, 3 x heat detector

First stage Sounder CCT : 10 x Maxitone sounder

First stage Sounder CCT: 1 x Megatone sounder

ITEM	QUIESCENT	ALARM
PREMIER EX8	160mA	200mA (350 for 2 nd stage)
MCP	0mA	40mA
OPTICAL	100uA	40mA
HEAT	50uA	40mA
MAXITONE SOUNDER	0mA	25mA
Megatone Sounder	0mA	250mA

To calculate the required battery backup required, we use the equation:-

$$\text{Battery Size (Standby time in Amp Hours)} = 1.25 \times [(T_{\text{ALM}} \times I_{\text{ALM}}) + (T_{\text{SBY}} \times I_{\text{SBY}})]$$

Where:

T_{ALM} = Maximum time in hours required for the alarm [$\frac{1}{2}$ hour is most common time]

I_{ALM} = Total Alarm Current in amps for all alarm devices connected to the alarm circuits

T_{SBY} = Standby time in hours for the system after mains failure [normally 24, 48 or 72 hr]

I_{SBY} = Quiescent current in amps of control panel in fault condition [because of mains failure] **PLUS** all detection zones.

Consider a 1st stage alarm

$$I_{\text{ALM}} = \text{PREMIER EX8 ALM} + 10 \times \text{MAXITONE ALARM} + 1 \times \text{DETECTOR ALM} + 4 \times \text{MCP QU} + 33 \times \text{OPT QU} + 4 \times \text{HT QU}$$

$$= 0.2 + 10 \times 0.025 + 1 \times 0.040 + 4 \times 0 + 33 \times 0.0001 + 4 \times 0.00005$$

$$= 0.2 + 0.25 + 0.04 + 0 + 0.0033 + 0.0002$$

$$= \mathbf{0.494 \text{ Amps}}$$

$$I_{\text{SBY}} = \text{PREMIER EX8 QU} + 10 \times \text{MAXITONE QU} + 7 \times$$

$$\text{MCP QU} + 34 \times \text{OPT QU} + 4 \times \text{HT QU}$$

$$= 0.160 + 10 \times 0 + 7 \times 0 + 34 \times 0.0001 + 4 \times 0.00005$$

$$= 0.160 + 0 + 0 + 0.0034 + 0.0002$$

$$= \mathbf{0.1636 \text{ Amps}}$$

Therefore:-

$$\text{Battery size} = 1.25 \times ((0.5 \times 0.494) + (24 \times 0.1636))$$

$$= 1.25 \times (0.247 + 3.9264)$$

$$= 1.25 \times 4.1734$$

$$= \mathbf{5.22 \text{ Ah}}$$

So 7.0 Ah batteries will be suitable for this installation

Consider a 2nd stage alarm

$$I_{\text{ALM}} = \text{as first stage, Plus 2nd stage sounders, Plus Bottle}$$

$$= \mathbf{0.494 + 250 + 1A \text{ for 5 min max (say = 0.167 equivalent)}}$$

$$= \mathbf{0.911 \text{ Amps}}$$

$$I_{\text{SBY}} = \text{as first stage}$$

$$= \mathbf{0.1636 \text{ Amps}}$$

Therefore:-

$$\text{Battery size} = 1.25 \times ((0.5 \times 0.911) + (24 \times 0.1636))$$

$$= 1.25 \times (0.4555 + 3.9264)$$

$$= 1.25 \times 4.3819$$

$$= \mathbf{5.477 \text{ Ah}}$$

So 7.0 Ah batteries will be suitable for this installation

Specifications

The EX8 has the following connections

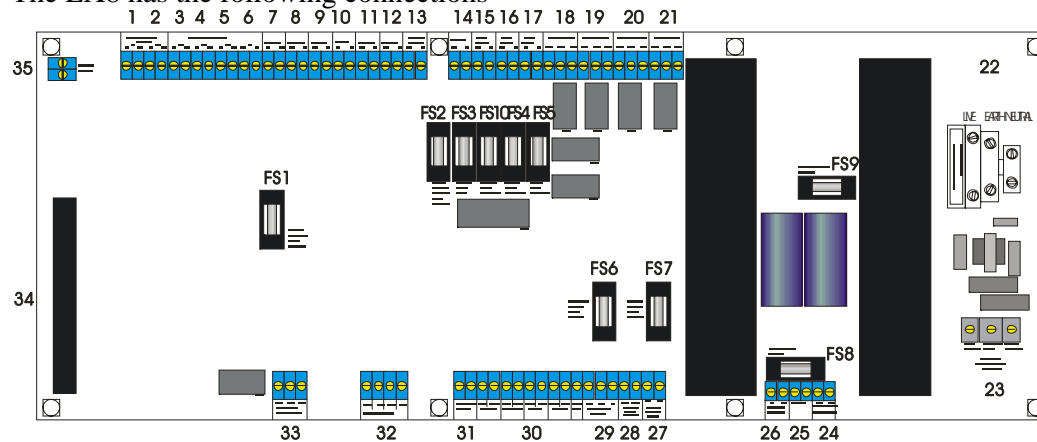

Conne ction	Label	Function
1	ZONE 1 +,-	FIRST CROSSED ZONE
2	ZONE 2 +,-	SECOND CROSSED ZONE
3	ZONE 3 +,-	FIRST PERIPHERAL ZONE
4	ZONE 4 +,-	SECOND PERIPHERAL ZONE
5	ZONE 5 +,-	THIRD PERIPHERAL ZONE
6	ZONE 6 +,-	FOURTH PERIPHERAL ZONE
7	GAS FD +,-	GAS FIRED INPUT (FROM BOTTLE)
8	MAN RL +,-	MANUAL RELEASE INPUT (TO MANUAL RELEASE MCP)
9	EM HLD +,-	EMERGENCY HOLD INPUT
10	AT/MN +,-	AUTOMATIC . MANUAL MODE INPUT
11	LOW PR +,-	LOW PRESSURE INPUT (FROM BOTTLE)
12	EM ABT +,-	EMERGENCY ABORT INPUT
13	BOT SC +,-	BOTTLE SCALES INPUT (FROM BOTTLE)
14	BOTTLE +,-	BOTTLE OUTPUT (TO BOTTLE SOLENOID)
15	1 ST SND A +,-	FIRST STAGE / FIRE SOUNDER CIRCUIT A
16	1 ST SND B +,-	FIRST STAGE / FIRE SOUNDER CIRCUIT B
17	2 ND SND +,-	SECOND STAGE SOUNDER CIRCUIT
18	1 ST ST AUX	FIRST STAGE RELAY NO/CM/NC CONTACTS
19	2 ND ST AUX	SECOND STAGE RELAY NO/CM/NC CONTACTS
20	GAS REL'D	GAS RELEASED CONFIRMATION RELAY (NO/CM/NC)
21	FAULT RLY	FAULT RELAY, NORMALLY ENERGISED
22	MAINS IN	230V AC FROM FUSED SUPPLY (NOT RCD)
23	XFO PRIM	FILTERED MAINS TO TRANSFORMER PRIMARY
24	XFO SEC	28V AC FROM TRANSFORMER SECONDARY
25	THERM	150K THERMISTOR (OVERCHARGE PROTECTION)
26	BAT +,-	2 X 12V SLA BATTERIES IN SERIES TO GIVE 24V DC
27	SER.SUP +,-	POWER TO SERIAL REPEATER
28	SER.DAT A,B	DATA TO SERIAL REPEATER
29	LED SUPPLY	28V SUPPLY TO -R REPEAT OUTPUTS
30	-R STATUS	STATUS INDICATIONS
31	CHASSIS ETH	EARTH POINT
32	REMOTE I/P	REMOTE INPUTS FOR STOP STOP/START SND, SILENCE, RESET
33	EXT.EQPT	EXTERNAL EQUIPMENT RELAY
34	TO DISPLAY	IDC CONNECTOR FOR DISPLAY
35	DOOR ETH	TO DOOR

Electrical Specifications

ELECTRICAL DESCRIPTION	VALUE
MAINS VOLTAGE	230V AC +/- 10% @ 50/60 Hz
BATTERY VOLTAGE	24V DC (2 X 12V SLA BATTERY)
SYSTEM VOLTAGE	24V DC NOMINAL (18 – 32 V)
SYSTEM VOLTAGE RIPPLE	2V PK-PK MAX
CHARGER SIZE	UP TO 7AH in 24 Hours
ZONE VOLTAGE	21V DC NOMINAL (20 - 22.5V)
1 ST STAGE SOUNDER ALARM OUTPUTS	2 x 150mA @ 24V DC (Nominal)
2 ND STAGE SOUNDER ALARM OUTPUTS	1 x 250mA @ 24V DC (Nominal)
AUXILIARY FAULT OUTPUT	1 x RELAY SELV (1A MAX) – NORMALLY ENERGISED
AUXILIARY 1 ST STAGE OUTPUT	1 x RELAY SELV (1A MAX)
AUXILIARY 2 ND STAGE OUTPUT	1 x RELAY SELV (1A MAX)
NUMBER OF ZONES	2 CROSSED ZONES 4 PERIPHERAL ZONES
MAXIMUM ZONE CAPACITY	32 DEVICES PER ZONE
MAXIMUM ZONE RESISTANCE	70 ohms
ZONE END OF LINE DEVICE	CROSSED ZONE – 2K7 RESISTOR PERIPHERAL ZONE – 100uF CAPACITOR
BOTTLE ACTIVATION DELAY	2 TO 59 SECONDS -IN 1 SEC INCREMENTS
BOTTLE END OF LINE DEVICE	10 K RESISTOR
SOUNDER END OF LINE DEVICE	10 K RESISTOR
MONITORED INPUT TRIGGER RESISTOR	470 OHM
MONITORED INPUT END OF LINE DEVICE	2K7 RESISTOR
CHARGER VOLTAGE	28.4V @ 25°C (NO BATTERY CONNECTED)
CHARGER SHORT CIRCUIT PROTECTION	Batteries less than 21V
TOTAL CHARGER OUTPUT	2.5 Amp

Enclosure Specifications

DESCRIPTION	VALUE
ENCLOSURE SIZE	480 x 395 x 100 mm
TOP CABLE ENTRIES	20 x 19mm DIA GROMMETED ENTRIES
BOTTOM CABLE ENTRIES	10 x 19mm KNOCKOUT ENTRIES
REAR CABLE ENTRIES	2 SNAP OUTS, 60 x 20mm

Fuse Ratings

FUSE NO	DESCRIPTION	RATING
FS1	Zone Monitoring Fuse	200mA time delay 5 x 20mm glass
FS2	Field Stat. Monitoring Fuse	100mA time delay 5 x 20mm glass
FS3	Bottle Fuse	1A time delay 5 x 20mm glass
FS4	First Stage Sounder B Fuse	150mA time delay 5 x 20mm glass
FS5	Second Stage Sounder Fuse	250mA time delay 5 x 20mm glass
FS6	Parallel Supply Fuse	150mA time delay 5 x 20mm glass
FS7	Serial Supply Fuse	100mA time delay 5 x 20mm glass
FS8	Battery Fuse	3.15A time delay 5 x 20mm glass
FS9	Charger Fuse	3.15A time delay 5 x 20mm glass
FS10	First Stage Sounder A Fuse	150mA time delay 5 x 20mm glass
INLET FUSE	Mains Protection Fuse	2A Quick Blow HBC 5 x 20mm ceramic

ALL OTHER EVENTS

DATE	TIME	ZONE / LOCATION	DETAILS OF EVENT (INCLUDING CAUSE IF KNOWN)	ACTION REQUIRED	DATE COMPLETED	INITIALS

Factory Test Record

Initial Setup

1. Turn on MAINS (panel shows Battery fault)
2. Set Battery charger voltage to 28.4V DC
3. Check Panel 5V rail is between 4.9 & 5.1V DC
4. Check Zone Voltage is between 18 & 20V DC
5. Connect Battery & check for Quiescent state.

Panel serial No	
PCB Version	
Build List Version	
Software Version	
DVM Serial Number	

Zone Status Check

(Panel is returned to quiescent after every test)

TEST	1 st stage A sounder	1 st stage B sounder	2 nd stage sounder	1 st stage aux relay	2 nd stage aux relay	Timer & bottle	Fault relay	Extract Relay	Rel.Stat. 1 st stage	Rel.Stat. flood zn fl	PR. 1 ST STAGE	PR. GEN FLT	Repeater Fire	Repeater Gas Imminent
Z1 O/C														
Z1 S/C														
Z1 FIRE														
Z2 O/C														
Z2 S/C														
Z2 FIRE														
Z3 O/C														
Z3 S/C														
Z3 FIRE														
Z4 O/C														
Z4 S/C														
Z4 FIRE														
Z5 O/C														
Z5 S/C														
Z5 FIRE														
Z6 O/C														
Z6 S/C														
Z6 FIRE														

Crossed Zones Test

(The 2 crossed zones are both set into alarm, and the outputs recorded)

Event	1 st Stage snd A	1 st Stage snd B	2 nd Stage snd	1 st aux relay	2 nd aux relay	Timer start	Bottle on	Bottle off	Gas Fired Rly	Timer end	Extract on	Repeater Fire	Repeater Gas Imminent	Repeater Gas Released
Zone 1 ALARM														
Zone 2 ALARM														
Wait timer 1														
Wait timer 2														
Gas Rel. Input														
Wait timer 3														
Reset														

Monitored Field Input Check

(Panel is returned to quiescent after every test)

TEST	PANEL OUTPUTS								PARALLEL REPEAT OUTPUTS								RELEASE STATUS INDICATIONS								SERIAL REPEATER INDICATION														
	1 ST STAGE A SOUNDER	1 ST STAGE B SOUNDER	2 ND STAGE SOUNDER	1 ST STAGE AUX RELAY	2 ND STAGE AUX RELAY	TIMER & BOTTLE	GAS RELEASED RELAY	EXTRACT RELAY	FAULT RELAY	PR. ABORT	PR. HOLD	PR. MAN REL	PR. BOTTLE OPERATED	PR. 2 ND STAGE	PR. 1 ST STAGE	PR. MANUAL	PR. AUTO	PR. GENERAL FAULT	R. ST. EXT. RELEASED	R. ST. HOLD/ABT	R. ST. 1 ST STAGE ALM	R. ST. LOW PRESS	R. ST. MANUAL MODE	R. ST. RELEASE IMM	R. ST. MANUAL REL	R. ST. 2 ND STAGE ALM	R. ST. FLOOD ZN FLT	R. ST. AUTO MODE	SR. AUTO MODE	SR. MANUAL MODE	SR. BOTTLE DISABLED	SR. HOLD ACTIVE	SR. ABORT ACTIVE	SR. MANUAL RELEASE	SR. FIRE	SR. GAS IMMINENT	SR. GAS RELEASED		
GAS FIRED																																							
MANUAL RELEASE																																							
EMERGENCY HOLD																																							
AUTOMATIC/MANUAL																																							
LOW PRESSURE																																							
EM ABORT																																							
BOTTLE SCALES																																							

Test Engineer: _____

Test Date: _____