

Triple(IR3) Flame Detector

Triple IR(IR3) - Model ZT-500EX

User and Maintenance Manual

47-153, Rev. A, Jul.25, 2012.



ZT-500EX



GLT Exports Limited

www.zetaalarmsystems.com

Warranty Statement

The GLT EXPORTS Optical Flame Detector described in this document is the property of GLT EXPORTS Inc.

No part of the hardware, software or documentation may be reproduced, transmitted, transcribed, stored in a retrieval system, or translated into any language or computer language, in any form or by any means, without prior written permission of GLT EXPORTS Inc.

While great efforts have been made to assure the accuracy and clarity of this document, GLT EXPORTS Inc. assumes no liability resulting from any omissions in this document, or from misuse of the information obtained herein. The information in this document has been carefully checked and is believed to be entirely reliable with all of the necessary information included. GLT EXPORTS Inc. reserves the right to make changes to any products described herein to improve reliability, function, or design, and reserves the right to revise this document and make changes from time to time in content hereof with no obligation to notify any persons of revisions or changes. GLT EXPORTS Inc. does not assume any liability arising out of the application or any use of any product or circuit described herein; neither does it convey license under its technical rights or the rights of others.

Warning:

This manual should be carefully read by all individuals who have or will have responsibility for using, maintaining or servicing the product.

The Detector is not field-repairable due to the meticulous alignment and calibration of the sensors and the respective circuits. Do not attempt to modify or repair the internal circuits or change their settings, as this will impair the system's performance and void the GLT EXPORTS Inc. Product warranty.

Certification Instructions

This section refers only for intrinsically safe installation on model ZT-500EX..
The following instructions apply to equipment covered by certificate number:
DNV 11 ATEX 02569X

- 1 The equipment may be used in a hazardous area with flammable gasses and vapors with apparatus groups IIC and with temperature class T6.
- 2 The equipment is certified for use in ambient temperatures in the range of -40°C to +75°C and should not be used outside the range.
- 3 Installation shall be carried out in accordance with the applicable code of practice by suitably trained personnel.
- 4 The equipment is not intended to be repaired by the user. Repair of this equipment shall be carried out by the manufacturer in accordance with the applicable code of practice.
- 5 If the equipment is likely to come into contact with aggressive substance, then it is the responsibility of the user to take suitable precautions that prevent it from being adversely affected, thus ensuring that the type of protection is not compromised.
Aggressive substances – e.g. acidic liquids or gases that may attack metals or solvents that may affect polymeric materials.
Suitable Precautions – e.g. regular checks as part of routine inspections or Establishing from the material's data sheet that it is resistant to specific chemicals.
- 6 The manufacturer should note that, on being put into service, the equipment must be accompanied by a translation of the instructions in the language of the country in which the equipment is to be used and by the instructions in the original language.
- 7 The instructions shall contain the certification marking as detailed on the relevant Certification drawing, _____.
- 8 Ensure that approved Ex d cable glands with IP67 ingress protection are used and installed according to the manufacturer's instructions.
- 9 The cable armour must be terminated in the gland or connected to the internal earth of the detector to ensure a positive electrical connection.
- 10 16 to 26 AWG (0.13 mm² to 1.5 mm²) wires may be used for site wiring.

11 Definition of ATEX Marking

CE 0575  II 2 G Ex d II C T6 DNV 11 ATEX 02569X
(1) (2) (3) (4)(5)(6) (7) (8) (9) (10) (11) (12)

- (1) CE Marking
- (2) Notified Body Number (0575: DNV)
- (3) European Commission mark for Ex-equipment
- (4) Equipment Group (II: Group for Offshore and surface Industries)
- (5) Equipment Category (Zone 1,2 / Zone 20, 21, 22)
- (6) G (Gas)
- (7) Type of protection (Ex d: Flameproof)
- (8) Gas Group (IIC: Hydrogen/Acetylene)
- (9) Temperature Class (T6: Maximum Surface Temperature: 85°C)
- (10) Name/ATEX Number of Notified Body (DNV 11)
- (11) ATEX
- (12) ATEX Certificate Number

TABLE OF CONTENTS

Warranty Statement.....	1
Warnings.....	1
Certification Instruction	2
1. Scope.....	7
1.1 PRODUCT OVERVIEW.....	7
1.2 DOCUMENT OVERVIEW.....	7
2. Technical Description.....	8
2.1 PRINCIPLES OF OPERATION.....	8
2.2 MODBUS RS-485.....	8
2.3 TYPES AND MODELS.....	8
3. Performance.....	11
3.1 DETECTION SENSITIVITY	11
3.2 CONE OF VISION.....	12
3.3 FALSE ALARMS PREVENTION.....	13
4. Operation.....	14
4.1 VISUAL INDICATIONS.....	14
4.2 OUTPUT SIGNALS.....	15
4.3 DETECTOR MODE SETUP.....	16
5. Technical Specifications.....	17
5.1 ELECTRICAL SPECIFICATIONS	18
5.2 MECHANICAL SPECIFICATIONS.....	19
5.3 ENVIRONMENTAL SPECIFICATIONS	20
6. Installation Instructions	21
6.1 SCOPE.....	21
6.2 GENERAL CONSIDERATIONS	21
6.3 PREPARATION FOR INSTALLATION	20
6.3.1 <i>Checking Detector</i>	22
6.3.2 <i>Interconnecting Cable Guidelines</i>	22
6.4 INSTALLATION.....	23
6.4.1 <i>Tilt Mount Kit</i>	23
6.4.2 <i>Tilt Mount</i>	23
6.5 DETECTOR MOUNTING.....	27
6.6 WIRING FUNCTION.....	27
7. Operating Instructions	28
7.1 SCOPE.....	28
7.2 POWER-UP.....	28
7.3 RESET... ..	28

7.4 FUNCTIONAL TESTING.....	28
7.4.1 Manual BIT Test.....	28
7.4.2 Testing with Fire Simulator.....	29
7.5 SAFETY PRECAUTIONS.....	29
8. Maintenance Instructions.....	30
8.1 SCOPE.....	30
8.2 MAINTENANCE INSTRUMENTATION AND PERSONNEL.....	30
8.3 PREVENTIVE MAINTENANCE PROCEDURES.....	30
8.4 PERIODIC MAINTENANCE PROCEDURES.....	30
8.4.1 Power-Up Procedure	30
8.4.2 Functional Test Procedure.....	30
8.5 MAINTENANCE RECORDS.....	30
8.6 TROUBLESHOOTING.....	31
8.6.1 Fault Indication	31
8.6.2 False Alarm or Warning Indication	31
Appendix A: Typical Wiring Configurations.....	32
Appendix B: Ordering Information.....	37

LIST OF FIGURES

<i>Figure 1: ZT-500EX IR3 Flame Detector</i>	<i>10</i>
<i>Figure 2: ZT-500EX IR3 Flame Detector Assembly - Outline Drawing - Cable output option..</i>	<i>10</i>
<i>Figure 3: Horizontal and Vertical Fields of View.....</i>	<i>12</i>
<i>Figure 4: ZT-500EX LED</i>	<i>14</i>
<i>Figure 5: Detector and Tilt Mount Assembly</i>	<i>24</i>
<i>Figure 6: Tilt Mount TM-ST10 Assembly - Outline Drawing.....</i>	<i>25</i>
<i>Figure 7: Tilt Mount TM-AL10 Assembly - Outline Drawing.....</i>	<i>26</i>
<i>Figure 8: Connector Interface</i>	<i>32</i>
<i>Figure 9: Cable Interface Option</i>	<i>33</i>
<i>Figure 10: RS-485 Networking.....</i>	<i>34</i>
<i>Figure 11: 4-20mA Wiring (Source Version).....</i>	<i>35</i>
<i>Figure 12: Typical Wiring For 4 Wire Controllers</i>	<i>36</i>

LIST OF TABLES

<i>Table 1: Response Sensitivity Ranges for other fuels</i>	<i>11</i>
<i>Table 2: Immunity to False Alarm Faults.....</i>	<i>13</i>
<i>Table 3: Output Signals/LED Indications versus Detector State</i>	<i>14</i>
<i>Table 4: DIP Switch Settings</i>	<i>16</i>
<i>Table 5: Contact Ratings</i>	<i>18</i>

1. Scope

1.1 Product Overview

The GLT EXPORTS Model ZT-500EX Triple IR(IR3) Flame Detectors is designed to sense the occurrence of fire and flames and subsequently activate an alarm or an extinguishing system, directly or through a control circuit for maximum fire protection. They use the innovative technology of advanced digital signal processing to analyze the dynamic characteristics of fire.

Detection performance is controlled by a microprocessor and easily adapted to all environments, applications and requirements.

ZT-500EX are for locations in Ex/ hazardous areas,

1.2 Document Overview

This manual describes the detector and its features and provides instructions on the installation, operation and maintenance.

This manual is divided into separate Sections as follows:

- Section 1.** **Scope** - a general introduction and overview of the Product and the Manual, with a brief description of its content.
- Section 2.** **Technical Description** - the detector's theory of operation.
- Section 3.** **Performance** - the detector features and capabilities.
- Section 4.** **Operation** - the detector's operation modes, user interface and indications.
- Section 5.** **Technical Specifications** - the Detector's electrical, mechanical and environmental specifications.
- Section 6.** **Installation Instructions**, including wiring and mode setting.
- Section 7.** **Operating Instructions** and power-up procedures.
- Section 8.** **Maintenance Instructions** and support procedures.
- Appendix A.** **Typical Wiring Configurations** - wiring diagrams for installation.
- Appendix B.** **Long Range Fire Simulator**
- Appendix C.** **Ordering information**

2. Technical Description

- **Triple IR Spectrum Channels** : 3 to 5 microns
- **Detection Range**: nom. 50m@1ft –sq Heptane
- **High Immunity to False Alarms** (see section. 3.3)
- **Field Programmable Sensitivity**: four ranges
- **Microprocessor Based**: Digital signal processing.
- **Built In Test (BIT)**: Manual and Automatic (*Options*)
- **Electrical Interface**:
 - Dry contact relays
 - 4-20mA output
 - Communication network RS-485 (OPTION)
- **Certifications**: ATEX for hazardous areas
KFI(Korea) / CE marking

2.1 Principles Of Operation

This version of IR3 Flame Detector is electronic devices designed to sense the occurrence of fire and flames and subsequently activate an alarm or an extinguishing system directly or through a control circuit.

The IR3 Radiation Flame Detector is a dual spectrum optical detector sensitive to two separate ranges of the radiation spectrum, both of which are present in fires. The detector monitors the protected area, by measuring the radiation intensity in it, within two frequencies ranges of the electromagnetic spectrum, namely three infrared(IR3) bands.

The detector integrates three dependent channels in which appropriate detection pulses are registered and further analyzed for frequency, intensity and duration.

2.2 Modbus RS-485

(to be specified later)

2.3 Types and Models

ZT-500EX has a enclosure of aluminium or optionally stainless steel(ST 316L), The output is via either a connector (socket) or a cable tail (up to 1m long).

Model Definitions

ZT-500 : IR3		-X	-X	-XX	-XX
EX : Ex/Metallic Enclosure		←			
<u>Cable Entries</u> 1 x M20	1		←		
<u>Housing</u> Aluminium	-	A		←	
<u>Approvals</u> ATEX	-	AT			←
FM	-	FM			
CE	-	CE			
Korean Type Approval	-	KR			
Non-certified	-	NC			

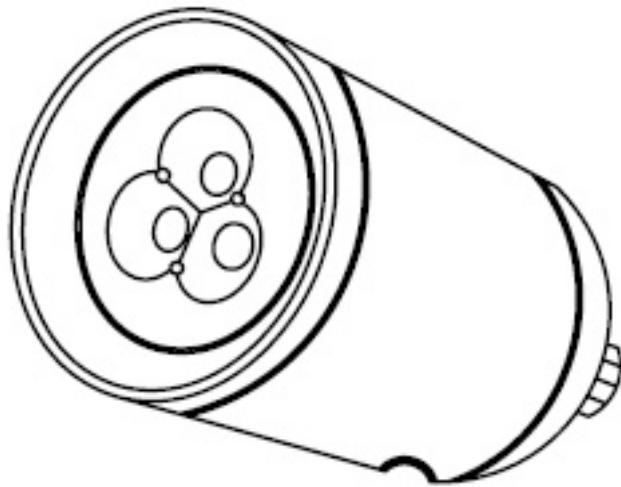

Figure 1: ZT-500EX IR3 Flame Detector

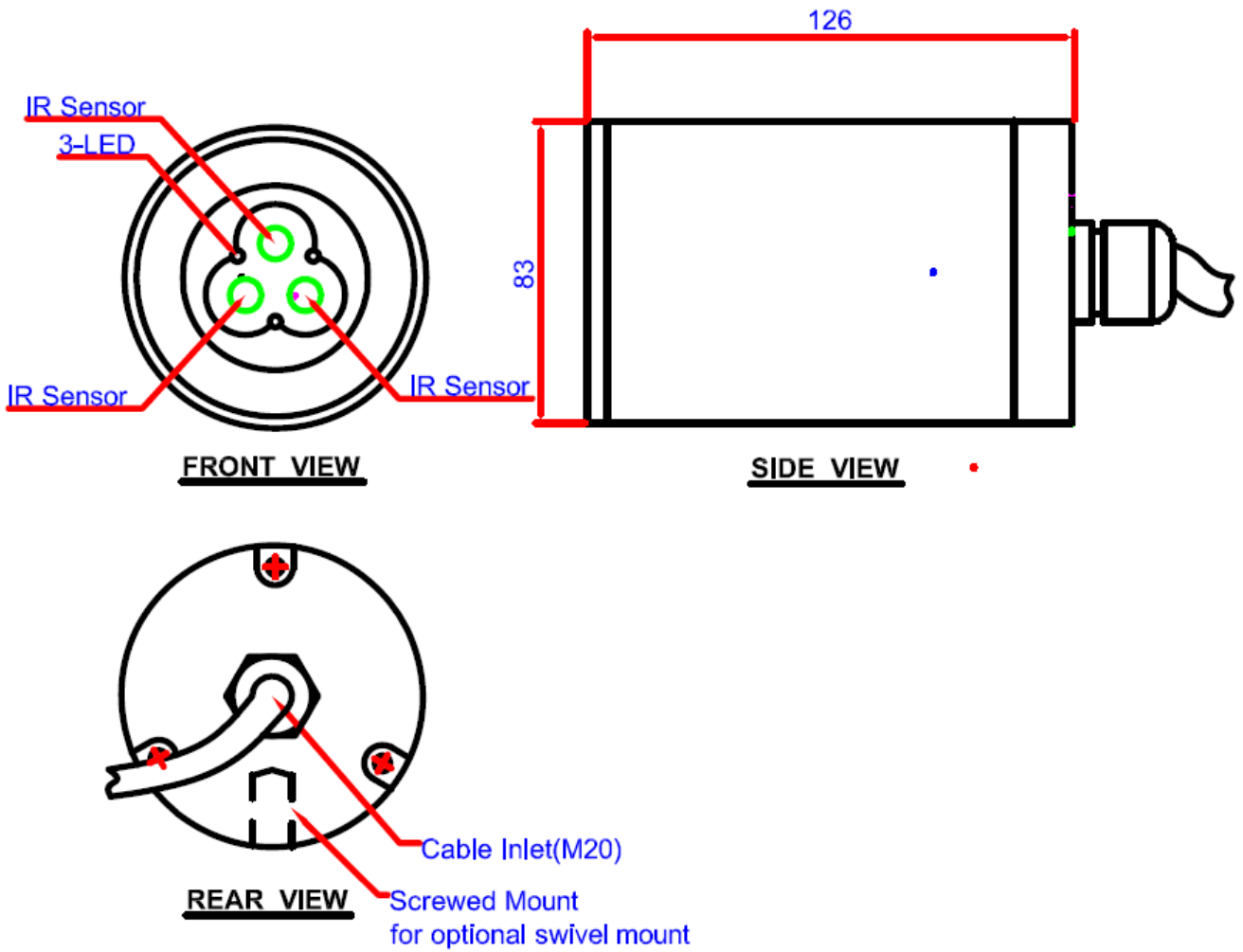

Figure 2: ZT-500EX IR3 Flame Detector Assembly - Outline Drawing - Cable output option

3. Performance

3.1 Detection Sensitivity

Detection sensitivity is the maximum distance at which the detector will reliably detect a specific size of fire & typical type of fuel (standard fire).

Standard Fire:

30cm x 30cm N-Heptane pan fire with max. wind speed of 6.5 ft/sec (2 m/sec).

Sensitivity Ranges:

The detector has the four(4) modes of user selectable sensitivity range. Alarm response times for a “standard fire” at a specified range are shown hereunder.

<ZT-500EX >

Detection Range (m): nom. 50 meters

Other fuels

The detector will react to other types of fires as follows:

Pan Fire Size: 1ft-sq(30cm x 30cm)

Maximum Wind Speed: 6.5 ft/sec (2 m/sec)

Maximum Response Time: 30 sec

Table 1: Response Sensitivity Ranges for other fuels

Type Of Fuel	Fire size	% Of Max. Distance
Gasoline	1ft ² (0.1m ²) pan fire	100
n-Heptane		100
JP4		70
Kerosene		70
Diesel Fuel		70
Alcohol 95%		60
IPA		60
Methanol		55
Methane		20" (0.5 m) Plume fire
LPG	20" (0.5 m) Plume fire	45
Paper	1ft ² (0.1m ²) pan fire	35
Polypropylene	1ft ² (0.1m ²) pan fire	15

3.2 Cone Of Vision

Horizontal: 90°

Vertical: 90°

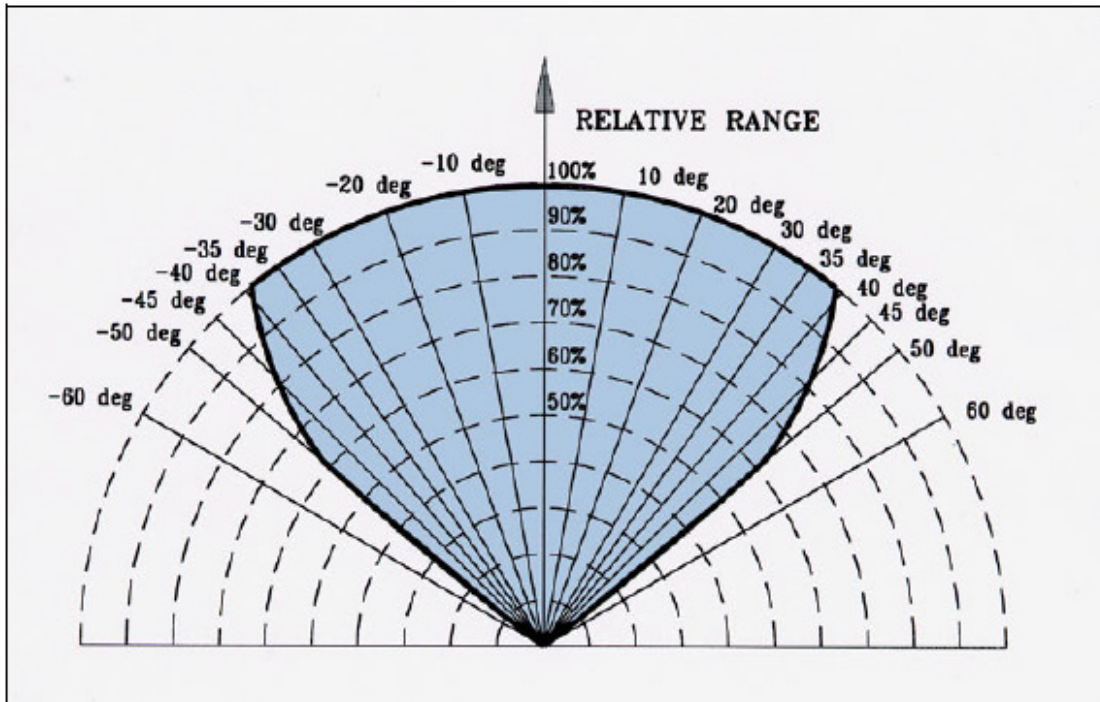

Figure 3: Horizontal and Vertical Fields of View

3.3 False Alarms Prevention

The detector will not provide an alarm signal as a reaction to the radiation sources specified below.

False alarm immunity is listed in Table 1.

Notes:

IAD = Immune at Any Distance.

All sources are chopped from 0 to 20Hz.

Table 2. Immunity to False Alarm Faults

Radiation Source Immunity	Distance ft. (m)
Sunlight	IAD
Indirect or reflected sunlight	IAD
Incandescent frosted glass light, 100W	IAD
Vehicle headlights (low beam) conforming to MS53023-1	IAD
Incandescent clear glass light, rough service, 100W	IAD
Fluorescent light with white enamel reflector, standard office or shop, 40W (or two 20W)	IAD
Arc welding [4mm (5/32in) rod; 240A]	9.8ft (3m)
Electronic flash (180 watt seconds minimum output)	IAD
Red dome light conforming to M251073-1	IAD
Blue-green dome light conforming to M251073-	IAD
Flashlight (Mx 991/U)	IAD
Radiation heater, 1500W	IAD
Radiation heater, 1000W with fan	IAD
Grinding metal	3.3ft (1m)
Lit cigar or cigarette	IAD
Match, wood, stick including flare up	3.3ft (1m)

4. Operation

4.1 Visual Indications

Three(3) LED-indicators are located in the detector front window:

Once powered up, the detector will begin appr. 20 sec start up routine.

During this time, all three(3) LED indicators will be Blinking.

Once the start up procedure has finished and no faults are present, the detector will begin Normal operation (Green LED will remain on).

Table 3: Output Signals/LED Indications versus Detector State

Detector Status	Green LED (Power)	Red LED (Alarm)	Yellow LED (Fault)	4-20mA Output <Optional>
Power up –20 second start delay	Blinking	Blinkings depend on DIP SW setting		2 mA
Internal Power Fault or system power out of range / Fault	Off	Off	Blinking	0 mA
Normal Operation	Solid	Off	Off	4 mA
Fire Detection(Warning)	Off	Solid	Off	16 mA
Fire confirmed	All LEDs blinking simultaneously			20 mA

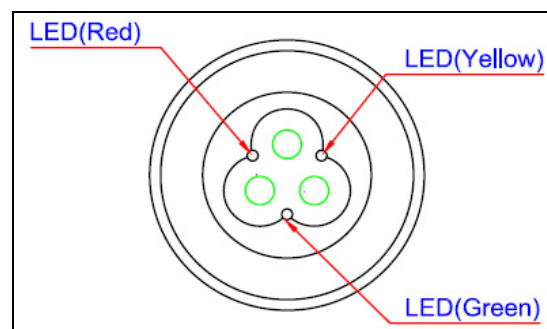

Figure 4: ZT-500EX LED

4.2 Output Signals

The detector provides the following outputs:

- Alarm relay
- Fault relay
- 4-20mA current output
- RS-485 communication (optional)

The detector can be in one of the following states.

Normal:	The detector is functioning normally.
BIT<Option>:	The detector performs a Built In Test.
Warning:	Fire detected – warning alarm (pre-alarm) state
Alarm:	Fire detected – fire alarm state
Latched Alarm (Selectable)	The alarm outputs are latched due to the detection of a fire that has already been extinguished.
BIT Fault<Option>:	A fault is detected during BIT sequence. The detector will continue to detect fire if the alarm conditions occur.
Fault:	A fault is detected when the power supply is too low or during a software fault.

4.3 Detector Mode Setup

Table 4: DIP Switch Settings

DIP Switch No.										Mode Selections
1	2	3	4	5	6	7	8	9	10	
<input checked="" type="checkbox"/>	<input checked="" type="checkbox"/>									Sensitivity Range (1) 0 0 : Highest 1 0 : High <Factory Default> 0 1 : Medium 1 1 : Low
		<input checked="" type="checkbox"/>	<input checked="" type="checkbox"/>							Alarm Delay Time (2) 0 0 : 0 sec 1 0 : 3 sec after alarm output 0 1 : 7 sec after alarm output 1 1 : 15 sec after alarm output<Factory Default>
				<input checked="" type="checkbox"/>	<input checked="" type="checkbox"/>					Alarm Latch Setting (3) 0 0 : Reset after 5 sec 1 0 : Reset after 10 sec 0 1 : Reset after 20 sec<Factory Default> 1 1 : Latch until external reset
						<input checked="" type="checkbox"/>	<input checked="" type="checkbox"/>			Reserved (for design setting) 1 0 : <Factory Default>
								<input checked="" type="checkbox"/>	<input checked="" type="checkbox"/>	Reserved (for design setting) 1 1 : <Factory Default>

Notes:

1. The detector offers four (4) sensitivity settings. The settings refer to the n-Heptane fire of 1ft-sq.
2. The Alarm delay option will affect the alarm relay and the 4-20mA output. When an Alarm (Detection) level condition is encountered, the detector delays the execution of the Alarm output relay by the specified period of time. The detector will then, additionally, evaluate the fire condition during the specified Alarm Delay Time. If the Alarm level is still present, the Alarm outputs will be activated. If this condition no longer exists, the detector will return to its standby state. The LED will indicate warning level during the delay time only if the fire condition exists.
3. The detector has an selectable latched alarm output capability, which operates according to the selectable function. If selected, upon the detection of a fire, the detection signal is latched until manually reset (disconnecting the power supply).

or performing a manual BIT). Latching affects the ALARM RELAY, 4-20mA output, the ALARM LED.

5. Technical Specifications

5.1 System Specifications

- **Certification:**
Exd – IIC T6, -40°C to +75°C (-40°F to +167°F)
IP67
- **Triple IR band wavelength:**
3 to 5 microns
- **Typical Alarm Activation Response Times*:**
ZT-500EX < 10 sec. : nom. 50m@30x30cm –sq Heptane
- **Field of View*:** (*Figure 3*)
Horizontal: 90°
Vertical: 90°
- **Sensitivity:**
- **Approvals:**
ATEX / CE Marking / KFI(Korea)
- **Warranty:**
Two Years

5.2 Electrical Specifications

A. **Operating Voltage:** nom. 24VDC(17-31 VDC)

B. **Power Consumption:**
Max. 35mA in Stand-by
Max. 75mA in Alarm

C. **Electrical outputs**

- **Dry Contact Relays:**

Table 5: Contact Ratings

Relay Name	Type	Normal position	Maximum Ratings
Alarm	SPDT	N.O., N.C.	5A at 30VDC or 10A at 250 VAC
Fault *	SPDT	N.C.	2A at 30VDC or 0.5A at 250 VAC

* The FAULT relay will be normally energized closed during normal operation of the detector. The contact will be open at Fault condition or low voltage

- **4-20mA Current Output.**

The 4-20mA works in non-isolated “source” version.
The maximum permitted load resistor is 800 ohm at 30Vdc
or 400 ohm at 20Vdc.

STATE	ZT-500EX Output (mA)	To
FAULT	0	+0.5mA
*BIT FAULT (Option)	2	±10%
NORMAL	4	±10%
IR Detect	8	±5%
UV Detect	12	±5%
WARNING	16	±5%
ALARM	20	±5%

- **Communication Network (option):**

The detector is equipped with an optional RS-485 communication link.
The details for this will be specified later.

D. Cable Wiring : “16 to 26” AWG (0.13 mm² to 1.5 mm²) wires to be used.

5.3 Mechanical Specifications

A. Enclosure options

- Heavy duty copper free aluminium with bright grey anodizing finish
- Stainless Steel 316L with electro polish finish (Option)

B. Water and dust tight

IP 67 per EN 60529

C. Electrical connection (two options)

1. 1 X M20 (ISO)

D. Dimensions

ZT-500EX : 83(Dia)mm × 126(L)mm
(w/o optional Tilt Mount)

E. Weight

Detector (aluminium) :appr. 1.1kg(1.4kg with Ex cable gland/2-meter cable)
Detector (stainless steel) :appr. 2.0kg(2.3kg with Ex cable gland/2-meter cable)

Tilt Mounts :0.3kg

5.3 Environmental Specifications

Operating temperature range: -40°C to +75°C (-40°F to +167°F)

Storage temperature range: -40°C to +75°C (-40°F to +167°F)

Humidity range: 0 to 95% RH non-condensing

Electromagnetic Compatibility (EMC):

This product is in conformance with EMC directive 89/336/EC.

Radiated Emission EN61000-6-3

Conducted Emission EN61000-6-3

Radiated Immunity EN61000-4-3

Conducted Immunity EN61000-4-6

ESD EN61000-4-2

Burst EN61000-4-4

Surge EN61000-4-5

6. Installation Instructions

6.1 Scope

The detectors are a self-contained Optical Flame Detectors designed to operate as a stand-alone units, directly connected to alarm systems or automatic fire extinguishing systems. The detectors can be part of a more complex system where many detectors and other devices are integrated through a common control unit.

This Section does not attempt to cover all of the standard practices and codes of installation. Rather, it emphasizes specific points of consideration and provides some general rules for qualified personnel. Wherever applicable, special safety precautions are stressed.

6.2 General Considerations

Very Important

The detector should be aimed toward the center of the detection zone and have a completely unobstructed view of the protected area. Whenever possible, the detector face should be tilted down at a slight angle to prevent the accumulation of dust and dirt. Do not start an installation unless all conceivable considerations regarding detector location have been taken into account.

To ensure optimal performance and an efficient installation, the following guidelines should be considered:

A. Sensitivity

To determine the level of sensitivity, the following issues should be considered:

- Size of fire at determined distance to be detected.
- Type of flammable materials.

B. Spacing and Location

The number of detectors and their locations in the protected area are affected by:

- Size of the protected area
- Sensitivity of the detectors
- Obstructed lines of sight
- Cone of view of the detectors

C. Environment

- Dust, snow or rain can reduce the detectors sensitivity and require more maintenance activities.
- The presence of high intensity flickering of IR sources may affect sensitivity.

6.3 Preparation for Installation

Installation should comply with local codes or something as applicable to flame detectors. The detectors can be installed with the use of general-purpose common tools and equipment.

6.3.1 Checking Detector

- 1 Verify the appropriate Purchase Order. Record the Part No. and the Serial No of the detectors and the installation date in the appropriate Log-book.
- 2 Open the container package prior to detector installation and visually inspect the detector.
- 3 Verify that all components required for the detector installation are readily available before commencing the installation. In case that the installation is not completed in a single session, secure and seal detectors and conduits.
- 4 For wiring, use color-coded conductors or suitable wire markings or labels. The 16 to 26 AWG (0.13 mm² to 1.5 mm²) wires may be used for site wiring. The selection of wire gauge should be based on the number of detectors used on the same line and the distance from the control unit, in compliance with specifications.

6.3.2 Interconnecting Cable Guidelines

- The flame detector requires an interconnecting cable with an overall screen (shield) and armour.
- Complete all cable insulation tests before connecting the cable at either end.
- The flame detector should be installed in accordance with the certification documents and the relevant regulations of the country concerned.
- Ensure that approved Exd cable gland with IP67 ingress protection are used and installed according to the manufacturer's instructions.
- The cable armour must be terminated in the gland or connected to the internal earth of the detector to ensure a positive electrical connection.
- The cable screens (drain wires) must not be connected electrically to the electronic circuitry of the flame detector.

6.4 Installation

The detector can be mounted on the wall preferably with the optional Tilt Mount. The Tilt Mount enables the detector to be rotated in all direction as the installer intends to do..

6.4.1 Tilt Mount Kit

-The detector can be mounted with one of two Tilt Mount Kits ;TM-ST10(Stainless) and TM-AL10(Aluminium) to be optionally selected by customers when ordering the detectors.

6.4.2 Tilt Mount (Figs. No. 5,6 and 7)

- 1 Place the Tilt Mount(item 3) in its designated location and secure it with four (4) fasteners through four (4) holes dia. 6.0mm (Fig. 9).Note: Skip this step if the Tilt Mount is already installed. Also detector removal for maintenance purpose does not require Tilt Mount removal.
- 2 Unpack the detector and the Tilt Mount.
- 3 Secure the detector with Tilt Mount by screwing the mounting pole of Tilt Mount completely into the detector.
- 4 Release the locking screw (item 4/5) in such a way that allows rotating the Detector which is combined with Mount Pole of Tilt Mount. Point the detector towards the protected area and make certain that the view of the area is unobstructed. Secure the detector in that position by tightening the locking screws (item 4/5) on the tilt mount. (Make sure the detector is in the correct position.)
Detectors should be mounted tilting downwards so that dust/moisture will not accumulate on the windows

The detector is now correctly located, aligned and ready to be connected to the system.

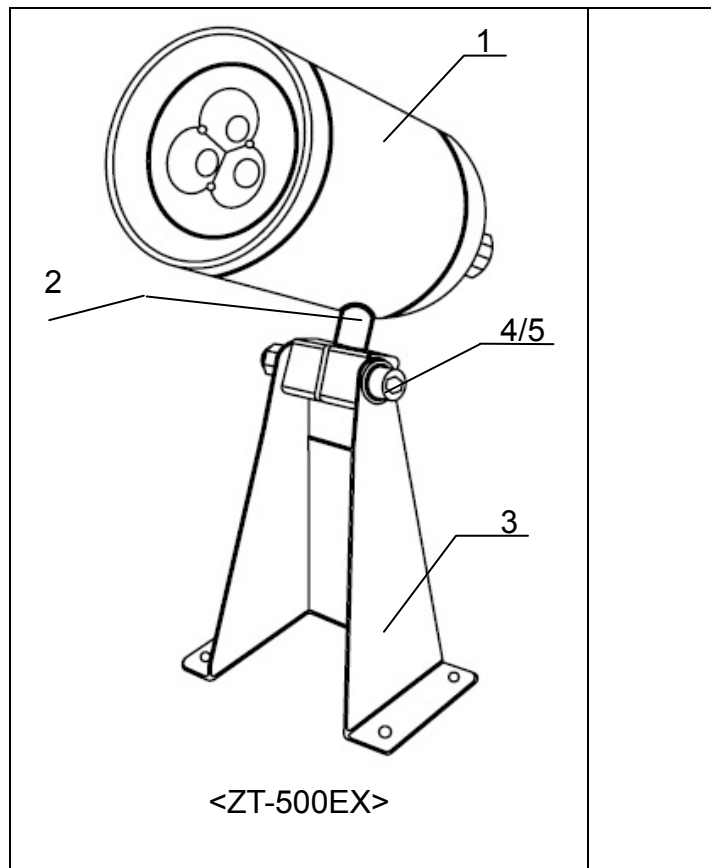

Description			
1	Detector	4	Locking Screw
2	Mounting Pole	5	Washers
3	Tilt Mount		

Figure 5: Detector and Tilt Mount Assembly

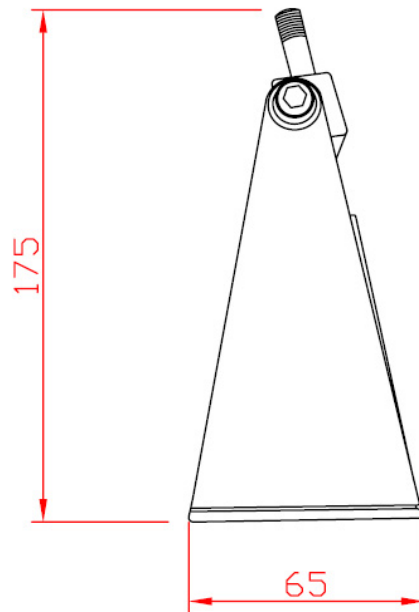
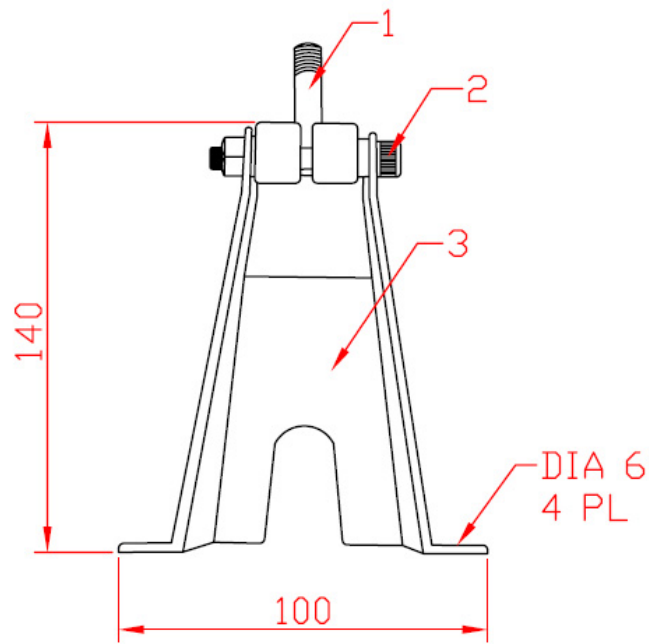

Description			
1	Mounting Pole	3	Tilt Mount
2	Locking Screw		

Figure 6: Tilt Mount TM-ST10 Assembly - Outline Drawing

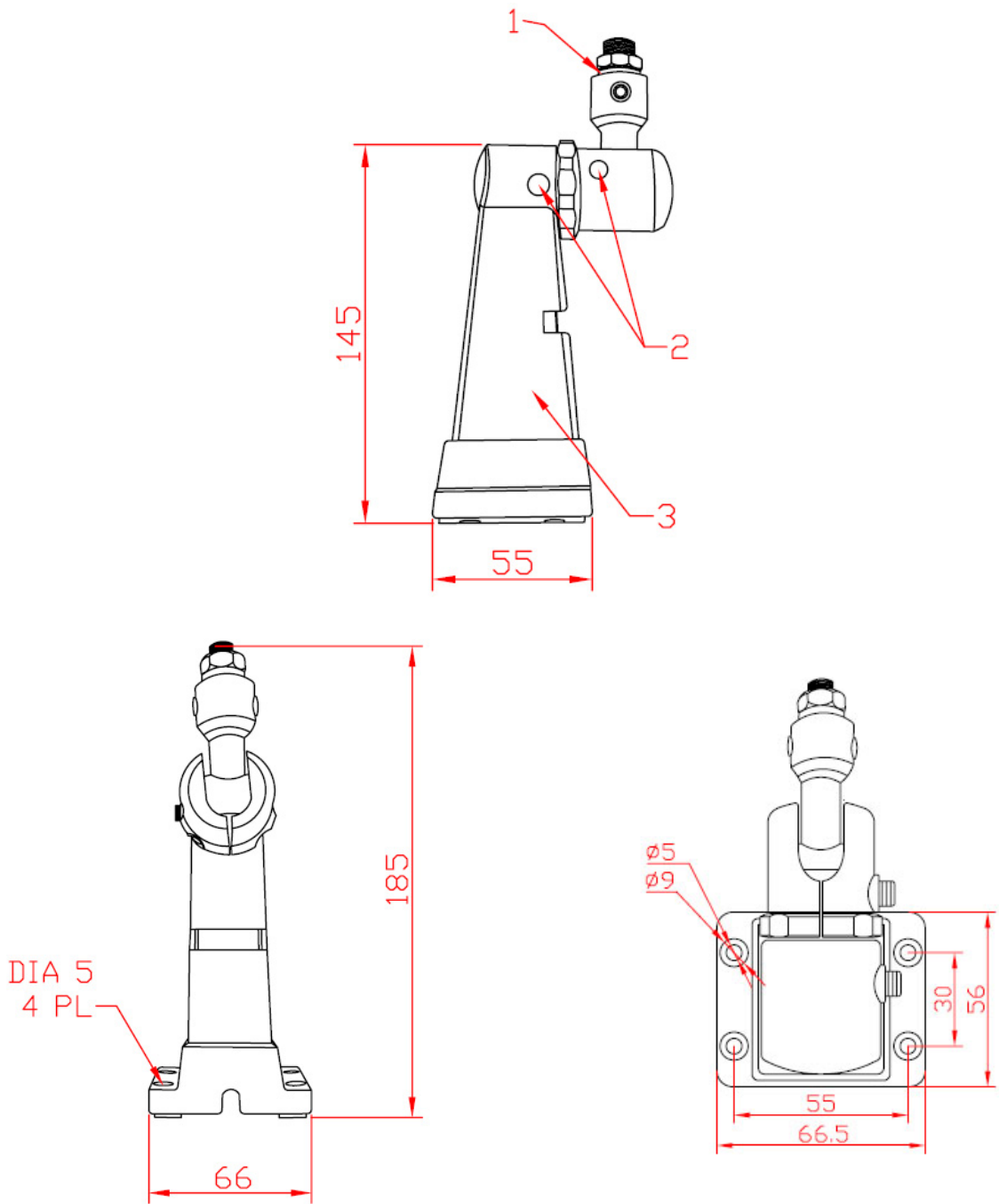

Description			
1	Mounting Pole	3	Tilt Mount
2	Locking Screw		

Figure 7: Tilt Mount TM-AL10 Assembly - Outline Drawing

6.5 Detector Mounting

- A. Choose the wiring configuration according to Appendix A.
- B. Connect the wire to the required PIN on the connector or choose the required color on the cable, according to your wiring diagram.
- C. Connect the grounding wire to general screw outside the detector, (Figs.2 and 3). The detector must be well grounded to earth ground for proper operation.

6.6 Wiring Function

(See Fig. No. 8 and No.9.)

The following describes the function of each electrical wire of the detector:

Power Supply

CN2 PIN No. 1 or red wire -Input Power

CN2 PIN No. 2 or black wire – Return(- :GND)

Manual Bit Activation

CN1 PIN No. 8 or violet wire - Manual BIT activation.

The manual BIT is initiated by a momentary connection of the 8 to the power supply Return line.

Fault Relay

The Fault output is a N.C. SPDT contact relay:

CN1 PIN No. 4 or yellow wire

CN1 PIN No. 3(COM) or green wire

The contact is normally energized closed when the detector is in its normal operational condition.

Alarm Relay

The Alarm output is a N.O./N.C SPDT contact relay.

CN1 PIN No. 1 or orange wire: N.C.

CN1 PIN No. 2 or white wire : N.O

CN1 PIN No. 3(COM) or green wire

4-20 mA Output (Option)

This output is used for analog, 4-20 mA current output.

CN1 PIN No. 7 or blue - output (-).

CN1 PIN No. 3(COM) or green wire

RS-485 (Option)

This output is used for communication network as specified in Appendix A.

CN1 PIN No. 5 or gray wire - positive (+) lead.

CN1 PIN No. 6 or pink wire - negative (-) lead.

7. Operating Instructions

7.1 Scope

The following instructions are designed to obtain optimal performance from the detector over its life cycle.

7.2 Power-Up

- 1 Apply power and wait approximately 20 seconds for the automatic self-test of the detector.
Note: Applying power initiates the following sequence:
 - All LEDs blink respectively.
 - BIT is executed, if successful then:
 - Only Green LED are solid(steady)
 - FAULT relay contacts close
- 2 Wiring Inspection: If a short-circuit or line discontinuity exists, indications will appear on LED initial status. Review your wiring.
- 3 The detector goes into its FAULT state when supply voltage drops below 16.5V. The detector status goes back to NORMAL, when the supply voltage is above 19V.
- 4 Detector Inspection: Visually inspect the viewing window of the detector. It should be clean and clear.
 - LED should be solid(steady) green
 - ALARM relays should be N.O
 - FAULT relay should be N.C
 - The 4-20mA Output should be 4mA.
- 5 If any of the outputs or indications is different from the description in step 4, see paragraph 8.6 for troubleshooting.

The Flame Detector is now ready for Functional Testing.

7.3 Reset (*only when optional 'latching' alarm has been selected*)

To RESET a detector when in its ALARM state, disconnect power, or initiate a manual BIT.

7.4 Functional testing

Following is a testing procedure for proper functioning of the detector. The detector can be tested using the Manual Built-in-Test or the GLT EXPORTS Fire Simulator (to be specified later).

7.4.1 Manual BIT Test

Momentarily connecting CN1-PIN 8 or pink wire with CN2-PIN 2 or black wire performs manual BIT.

7.4.2 Testing with Fire Simulator (to be released later)

To be additionally instructed later.

7.5 Safety Precautions

After Powering-up, the detector requires hardly any attention in order to function properly, but the following should be noted:

- 1 Follow the instructions in the manual and refer to the drawings and specifications issued by the manufacturer.
- 2 Do not expose the detector to radiation of any kind unless required for testing purposes.
- 3 Do not open the detector housing, while power is supplied.
- 4 Do not touch internal parts other than the DIP switch..
Interference with internal circuits may impair detector performance and will invalidate manufacturer's Warranty.
- 5 Disconnect external devices, such as automatic extinguishing systems before carrying out any maintenance.

8. Maintenance Instructions

8.1 Scope

This Section deals with preventive maintenance, describes possible faults in detector operation and indicates corrective measures. Ignoring these instructions may cause problems with the detector and may invalidate the warranty. Whenever a unit requires service, please contact the manufacturer or its authorized distributor for assistance.

8.2 Maintenance Instrumentation and Personnel

Detector maintenance requires ordinary tools and suitably qualified personnel, who should be familiar with local codes and practices.

8.3 Preventive Maintenance Procedures

The detector must be kept as clean as possible. The detector's viewing window and the reflector must be cleaned periodically. The frequency of cleaning operations depends upon the environmental conditions and specific applications. The fire detection system designer will give his recommendations.

- 1 Disconnect power to the detector before proceeding with any maintenance including lens cleaning.
- 2 To clean the detector viewing window and reflector, use water and detergent then rinse with clean water.
- 3 Where dust, dirt or moisture accumulates on the window, first clean with a soft optical cloth and detergent then rinse with clean water.

8.4 Periodic Maintenance Procedures

In addition to preventive cleaning and maintenance, the detector should be functionally tested every six months. This test should also be carried out if, for any reason, the detector has been opened.

8.4.1 Power-Up Procedure

Perform Power-Up procedure every time power is restored to the system. Follow the instructions in paragraph 7.2.

8.4.2 Functional Test Procedure

Perform a functional test of the detector as described in paragraph 7.4.

8.5 Maintenance Records

It is recommended to record maintenance operations performed on a detector in a system Log-book. The record should include information, which identifies the unit, the installation date, contractor, and entries for every maintenance operation performed including the description of the operation, date and personnel ID. If a unit is sent to the manufacturer or distributor for service, a copy of the Maintenance records should accompany it.

8.6 Troubleshooting

8.6.1 Fault Indication

- 1 Check power supply for correct voltage, polarity and wiring.
- 2 Check detector window and reflector for cleanliness. If necessary clean the window as indicated in paragraph 8.3 and repeat the test.
- 3 Disconnect the power supply to the system and check the detector's internal wiring.
- 4 Reconnect power supply and wait approximately 10 seconds. Repeat the test. If the Fault LED is still flashing (1 Hz) yellow, the unit requires service.

8.6.2 False Alarm or Warning Indication

- 1 Disconnect the power supply from the system and check internal wiring.
- 2 Reconnect power supply and wait approximately 60 seconds. If indication remains, the unit requires service.

Appendix A: Typical Wiring Configurations

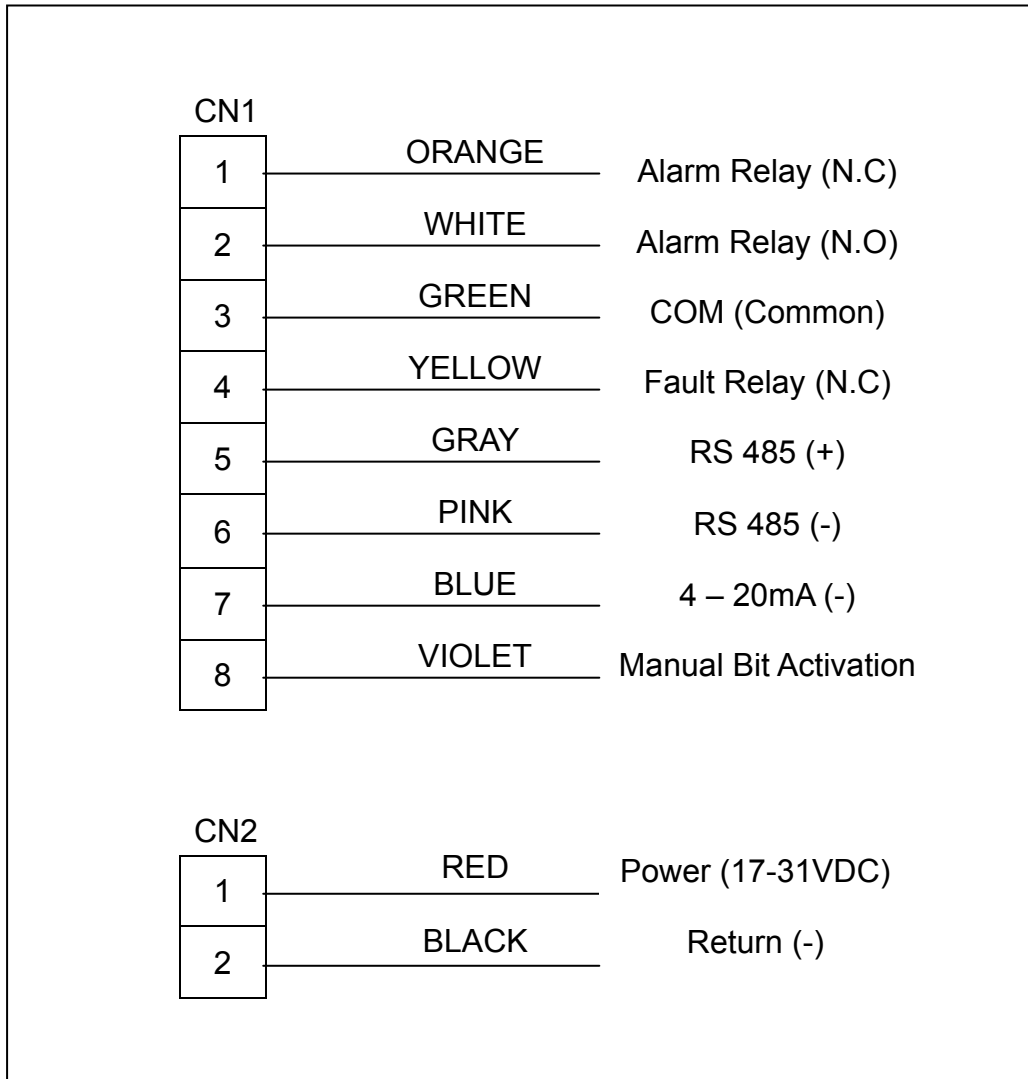

Figure 8: Connector Interface

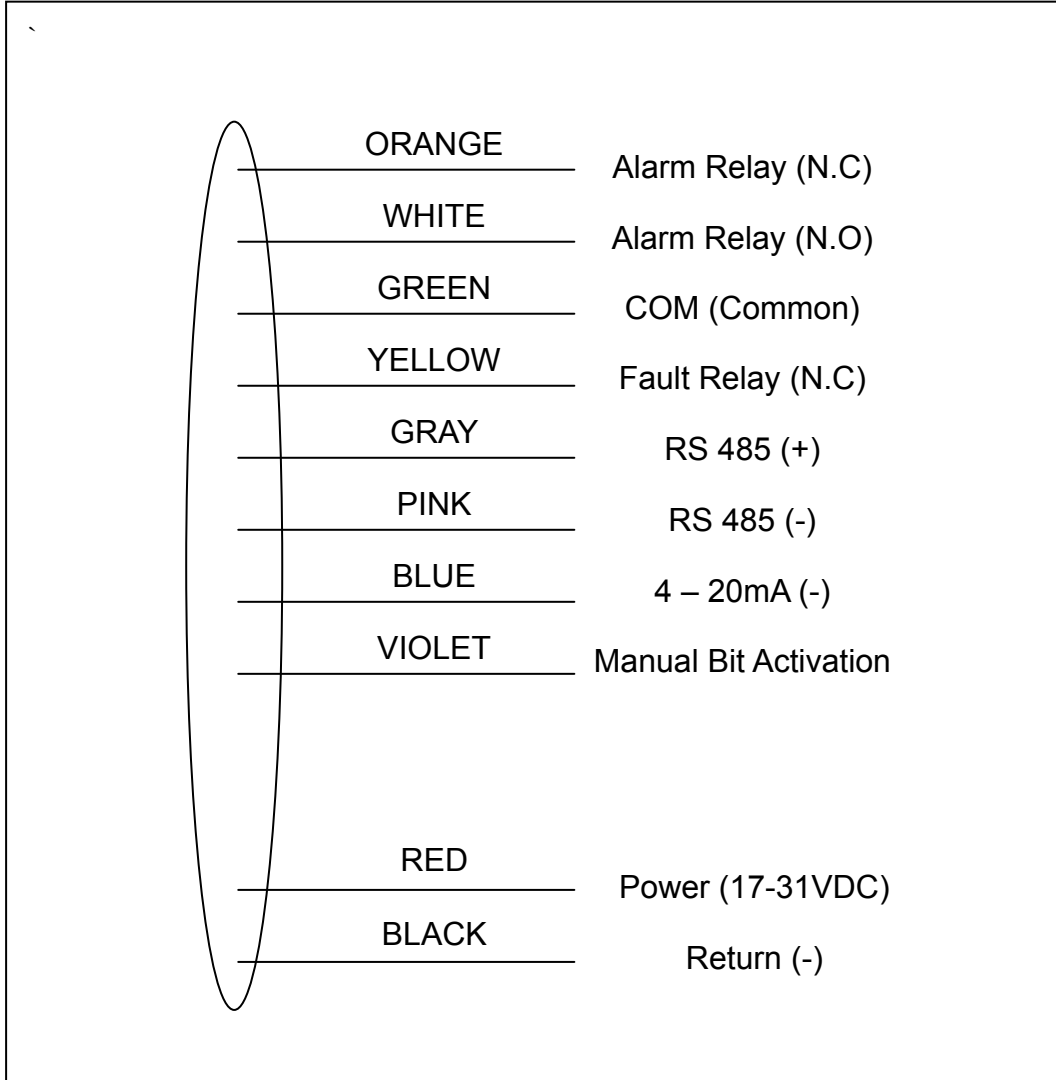

Figure 9: Cable Interface Option

RS-485 Communication Network

For more details, consult the factory.

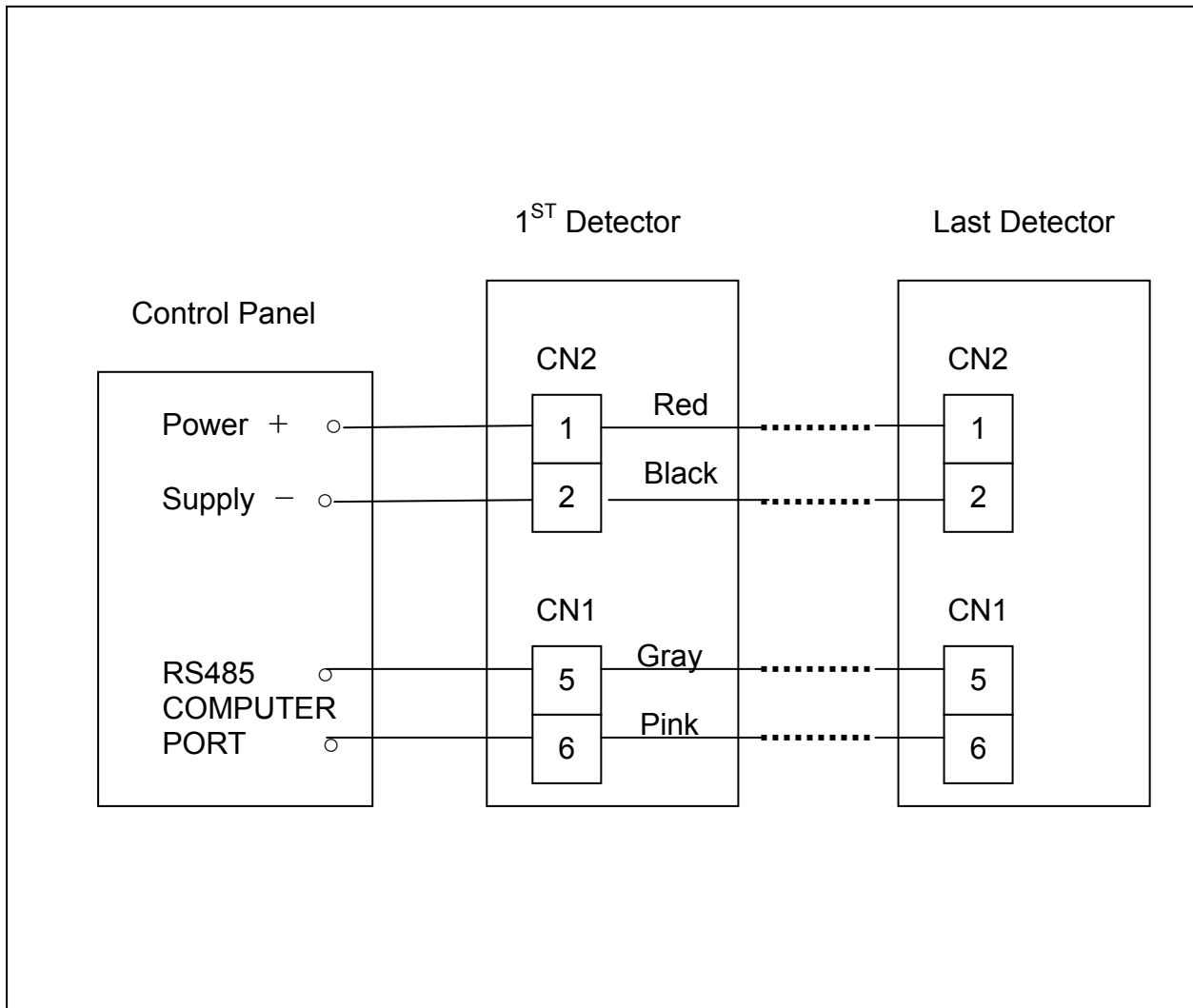

Figure 10: RS-485 Networking

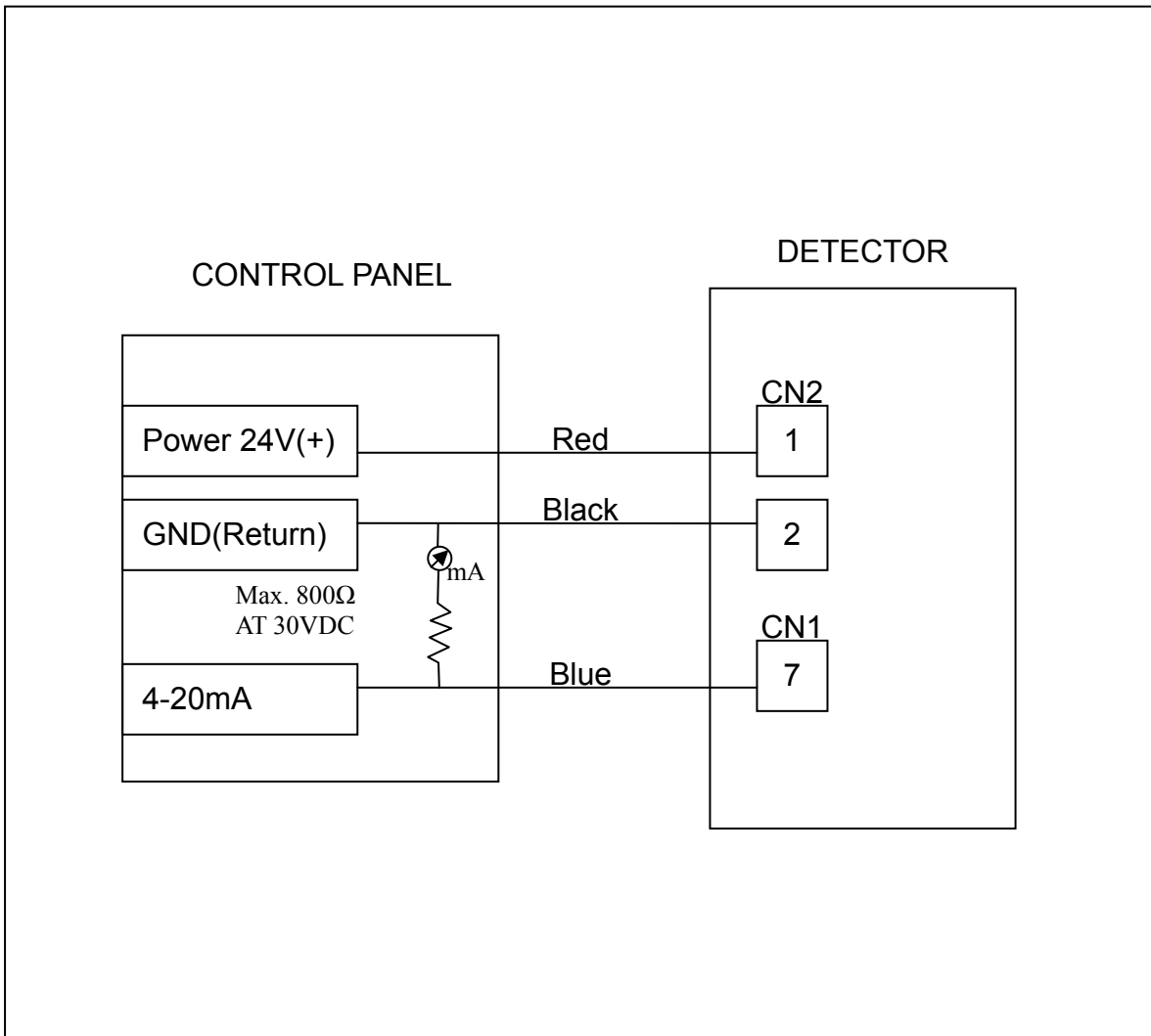

Figure 11: 4-20mA Wiring (Non-isolated “SOURCE” Version)

Notes: The 4-20mA will be measured between CN1 PIN 7 or blue wire and CN2 PIN 2 or black wire.

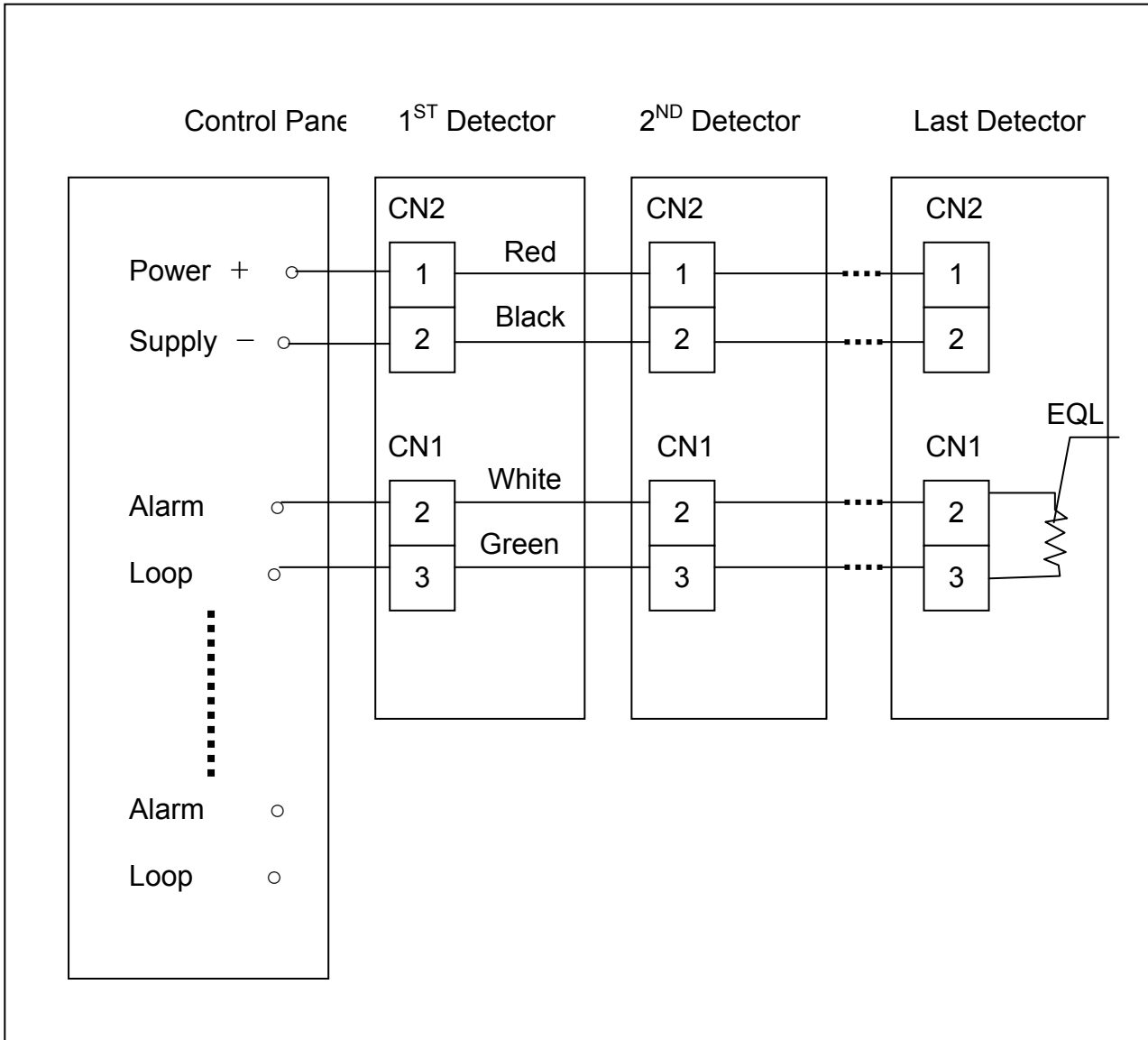

Figure 14: Typical Wiring For 4-Wire Control Panel

Notes:

- 1 For EOL resistor value see Controller Manual (ex: 10k ohms)
- 2 The color wire refers to the color of the cable output option. The PIN No. Refer to the connector option.
3. In case of one circuit in multi-circuits controller ,connecting to only one detector, EQL should be installed respectively to all each detectors.
4. The entire length of wiring between the detector and control panel should be less than 30 meters, considering the EMC performance of the detector..

Appendix B: Ordering Information

Please define the requested model according to 1.1.5 by filling in the appropriate squares below.

Model Definitions				
ZT-500EX		-X	-X	-XX
EX : Ex/Metallic Enclosure		←		
<u>Cable Entries</u>				
1 x M20	1	←		
<u>Housing</u>				
Aluminium	-	A	←	
<u>Approvals</u>				
ATEX	-	AT	←	
FM	-	FM		
CE	-	CE		
Korean Type Approval	-	KR		
Non-certified	-	NC		

If you need a special set up, please refer to Section 3.2 to complete the following table:

SENSITIVITY	<input type="checkbox"/>	ALARM LATCH	<input type="checkbox"/>
ALARM DELAY	<input type="checkbox"/>	AUTOMATIC BIT	<input type="checkbox"/>

Orders may be sent to:

GLT Exports Ltd.

72/78, Morfa Road, Swansea, SA1 2EN, United Kingdom.

Tel) +44 (0) 1792 455175 Fax)+44 (0) 1792 455176

For additional details or assistance, please contact



GLT Exports Ltd.

72/78, Morfa Road, Swansea, SA1 2EN, United Kingdom.

Web-Site: www.zetaalarmssystems.com

Tel) +44 (0) 1792 455175 Fax)+44 (0) 1792 455176

Your Local Authorized Distributor: