

PEBS2000

Emergency Evacuation System

Operation Manual

INDEX

Caution.....	3
INTRODUCTION.....	4
Basic Operation Description.....	4
PEBS CONTROLS & INDICATIONS.....	5
Description of Control Keys and LED Indicators.....	6
Mounting the PEBS system to a Wall.....	7
Installation and Commissioning.....	8
System Line Diagram.....	8
Wiring a PEBS System.....	8
Connecting to mains.....	8
Connecting the Speaker Circuits (Broadcast Area Output Terminals).....	9
Connecting the Remote Control Connections.....	9
Connecting the Remote Microphone Input.....	9
Connecting the Battery.....	10
CONFIGURING THE PEBS SYSTEM.....	11
Recording an Alert Message.....	11
Recording an Evacuate Message.....	11
Changing the Alert tone ****NOT RECOMMENDED****.....	11
Changing the EVACUATE tone ****NOT RECOMMENDED****.....	12
Automatic operation of PEBS.....	12
Message format.....	14
NETWORKED SYSTEMS.....	15
Using the Remote microphone operation button and indication light.....	16
Product Specifications.....	17
(1) PEBS2000 Main Unit.....	17
(2) PEBS1000 Main Unit.....	18
(3) Broadcast Line Terminal Device (ESEOL).....	19
(4) Remote Microphone (RMM2000).....	19
(5) 10 Way Master Microphone.....	20
(6) Broadcast Speaker (CS3).....	20
(7) Network data decode module (GXE0-2050-D).....	21
(8) Remote control module PCB (GXE0-224E-C).....	21
(9) Remote microphone terminal.....	22
12. Fault Analysis and Rectification.....	23
13. Storage Environment Requirements.....	23

Caution

Thank you for choosing our Fire Emergency Broadcast System. Please be sure to read this manual carefully before installation and use. Keep this manual nearby for reference whenever necessary.

We reserve the right to make changes at any time without prior notice.

1. Be sure to familiarize yourself with this manual and perform all operations according to instructions.
2. Use of 230V AC power supply. Ground the box well to ensure the personal safety of users.
3. Keep the main set from heat source, e.g. air conditioner or heater for proper ventilation and cooling.
4. Scope of application Main set, broadcast line terminal device and speakers must be used in matched set. Damage or other unexpected consequences will be caused as a result of improper use.
5. Wait half an hour before powering up if the equipment is moved from outside into a room.
6. Avoiding from exposing main set to the sun. When the ambient temperature exceeds 50°C, permanent damage will be caused.
7. Do not install the system in areas that are damp or humid, e.g. basement and other similar places.
8. Maintenance

There are no user serviceable components in this unit. Trained personnel are required for maintenance

INTRODUCTION.

The Premier Emergency Broadcast System (PEBS) is available in 2 versions:-

- The Original 4 channel unit with 300W total output – 75W/channel(PEBS 2000)
- And the 2 Channel unit with a total of 50W total output – 25W/channel (PEBS 1000)

These panels can be used in stand alone mode with a Standard Remote Microphone Unit

All panels made in 2009 or later have the option to be networked. To work in Network mode, each panel has to be connected to a 10 way remote Microphone unit. There can be up to 10 units on the network, with any combination of 2 channel or 4 channel units.

The total number of speakers that can be connected will depend on the model of PEBS, and also the model of speaker. Zeta Alarm Systems supply speakers from 0.5W ceiling speakers to 10W outside horn speakers.

The PEBS systems have 2 pre-recorded messages that can be triggered manually or automatically. They also have a live broadcast microphone that can be used to broadcast evacuation details.

Each channel needs an Emergency System End Of Line (ESEOL) unit fitted

The PEBS system has a built in speaker (for monitoring what is broadcast to the speaker lines). The volume of this speaker is adjustable with the panel control buttons

This system is not suitable for use in hazardous areas.

Basic Operation Description

The PEBS system has been designed to provide the following functions:-

1. Make a live broadcast using the inbuilt mic, or a remote microphone unit.
2. Play back a pre-recorded message (started manually at the unit)
3. Play back a pre-recorded message (started remotely via a fire alarm panel)

The Channels to be broadcast can be selected at the panel, or via the remote inputs.

If the remote channel select lines are not used, the channels should be selected by default.

Each PEBS control panel can only broadcast one message at a time, because the speaker lines share a common amplifier.

PEBS CONTROLS & INDICATIONS

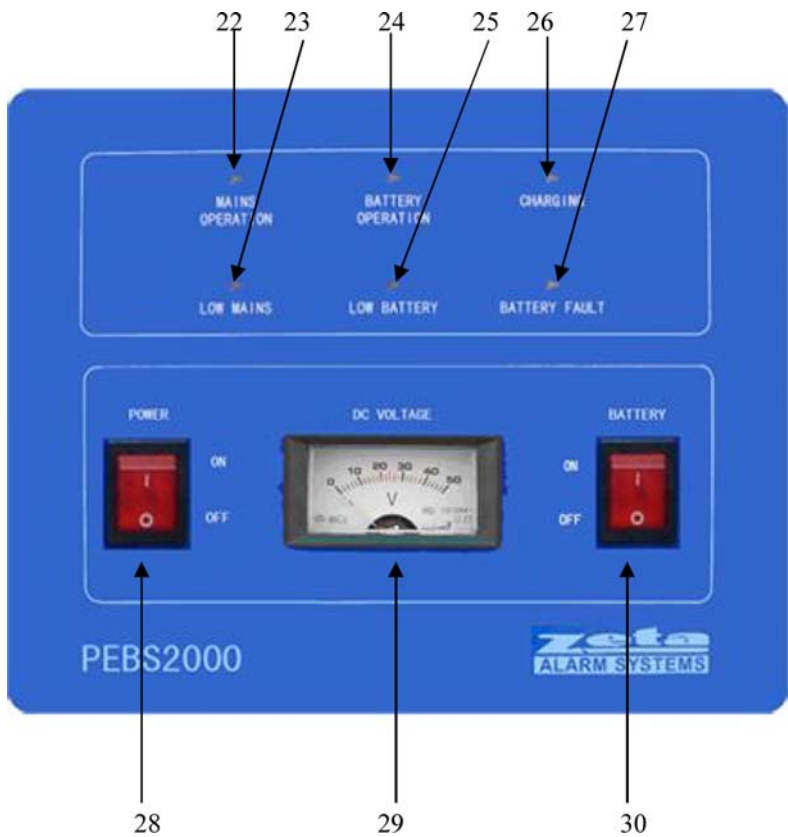
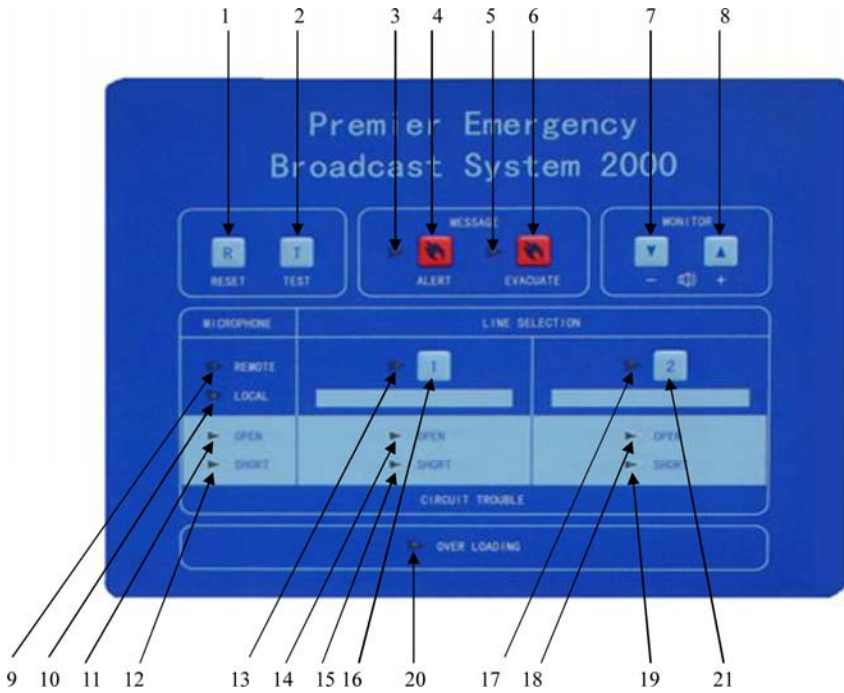

Description of Control Keys and LED Indicators

No	Name of Components		Function/Instruction
1	Reset Key	C	Stop playing alert or evacuation message
2	Test Key	C	Test the operation state of indicators and speakers
3	Alert Message LED (Red)	L	Indicates alert message is playing
4	Alert Message Play Key	C	Starts playing pre-recorded alert message
5	Evacuation Message LED (Red)	L	Indicates evacuation message is playing
6	Evacuation Message Play Key	C	Starts playing pre-recorded evacuation message
7	Volume Down Key	C	Turn down internal speaker monitoring volume
8	Volume Up Key	C	Turn up internal speaker monitoring volume
9	Remote Mic Operation LED (Red)	L	Indicates the operation of remote microphone
10	Local Mic Operation LED (Red)	L	Indicates the operation of local microphone
11	Microphone Open Circuit LED (Yellow)	L	Open circuit of local or remote microphone (with microphone indicator)
12	Microphone Short Circuit LED (Yellow)	L	Short circuit of remote microphone together with microphone indicator
13	Broadcast Area 1 Operation LED (Red)	L	Indicates broadcast area 1 output selected
14	Broadcast Area 1 Open Circuit LED (Yellow)	L	Open circuit Fault on broadcast area 1
15	Broadcast Area 1 Short Circuit LED (Yellow)	L	Short circuit Fault on broadcast area 1
16	Broadcast Area 1 Start/Stop Key	C	Select / Cancel broadcast area 1 output
17	Broadcast Area 2 Operation LED (Red)	L	Indicates broadcast area 1 output selected
18	Broadcast Area 2 Open Circuit LED (Yellow)	L	Open circuit Fault on broadcast area 2
19	Broadcast Area 2 Short Circuit LED (Yellow)	L	Short circuit Fault on broadcast area 2
20	Power Amplifier Overload LED (Yellow)	L	Critical loading or overload protection alarm of power amplifier
21	Broadcast Area 2 Start/Stop Key	C	Select / Cancel broadcast area 2 output
22	Mains Operation LED (Green)	L	Indicates Mains Power present
23	Mains Low Voltage LED (Yellow)	L	Mains Low voltage fault warning
24	Standby Power Operation LED (Green)	L	Indicates Battery Power present
25	Battery Low Voltage LED (Yellow)	L	Battery Low voltage fault warning
26	Charging State LED (Green)	L	Indicates normal battery charging
27	Battery Fault LED (Yellow)	L	Open/short circuit fault warning of battery lead
28	Mains Switch	C	Connects mains power to unit
29	Direct Current Voltmeter		Indicates voltage of power supply (D.C.)
30	Standby Power Supply Switch	C	Connects battery power to unit

C= Control Key

L = LED indicator

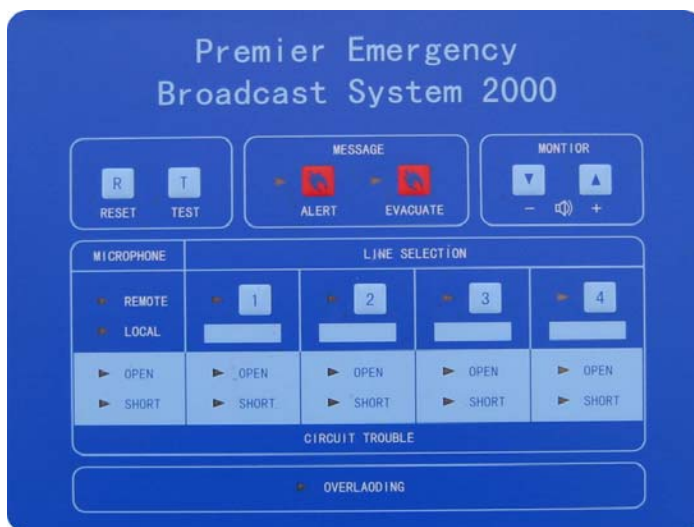

Note: The PEBS2000 has the same controls & Indicators, apart from the extra broadcast area parts for the extra areas 3 & 4.

Mounting the PEBS system to a Wall

The PEBS Main units are quite heavy (20 kg for 2 channel PEBS1000, or 34 kg for 4 channel PEBS2000). Take care to ensure that both the wall and the proposed fixing screws will be suitable.

Mount the PEBS unit on firm wall with 4 steel bolts with cross-section at least 8mm.

Mount the remote microphone (RMM2000, or 10 way microphone) on firm wall with 4 steel bolts with cross-section at least 6mm.

Installation and Commissioning

System Line Diagram

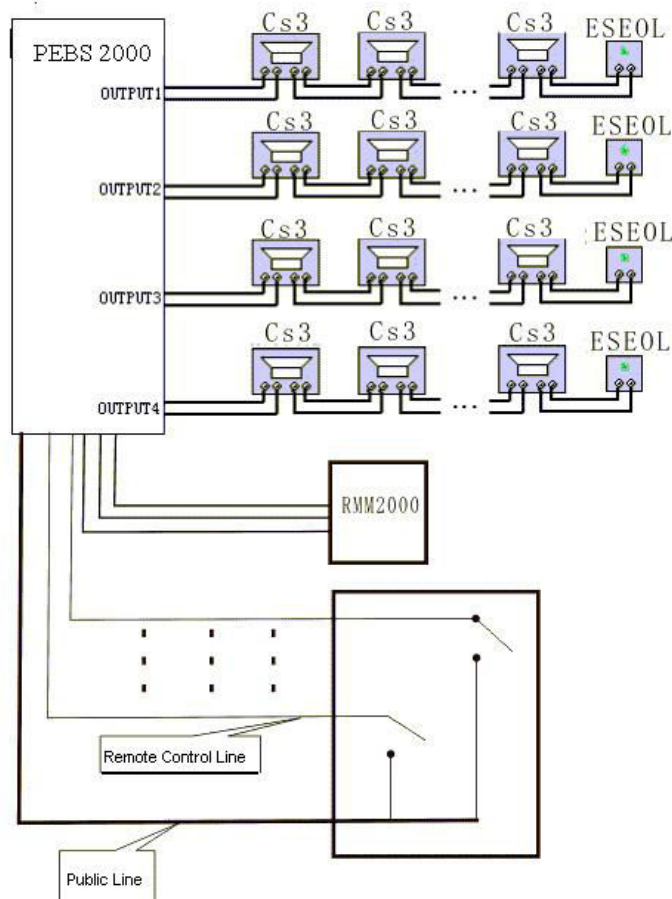

Wiring a PEBS System

Connecting to mains.

The mains power connection is located in the right top side of inside box. Please connect the input line of AC power supply to the corresponding terminal according to following illustration. After ensuring that the wires are fitted to the correct terminal, and are fitted tight, replace the terminal protective cover. It is recommended that the mains connection is made with fire resistant cable, such as our Fire Defense Cable, with a core cross section of at least 1.5 mm².

Connecting the Speaker Circuits (Broadcast Area Output Terminals)

The broadcast area output terminal is located to the left side of the mains power terminal. Please connect the wire of broadcast area that you need to the corresponding terminal according to following illustration. To ensure the transmission distance of audio broadcast signal, we suggest flame-retardant copper cord wire which cross-section is large than 1 mm². Meanwhile, keep distance away from equipments which have the capability of generating electromagnetic interference.

Connecting the Remote Control Connections.

The remote control input terminal is located to the left side of broadcast area output terminal. Please connect the remote control input wire to the corresponding terminal according to following illustration.

It is recommended that the remote control connection is made with fire resistant cable, such as out Fire Defense Cable, with a core cross section of at least 1.0 mm².

It is recommended to keep distance away from equipment which has the capability of generating strong electromagnetic interference.

There are controls for:-

- Select Channel 1
- Select Channel 2
- Select Channel 3
- Select Channel 4
- Select Alert Message
- Select Evacuate Message

Connecting the Remote Microphone Input.

The remote microphone input terminal is located to the left side of remote control input terminal. Please connect the input wire of remote microphone that you need to the corresponding terminal according to following illustration. To reduce the interference of ambient environment in audio signal, use a 2 core screened cable. Connect the metal cover to the negative electrode of DC24V power source, and keep distance away from equipments which have the capability of generating strong electromagnetic interference.

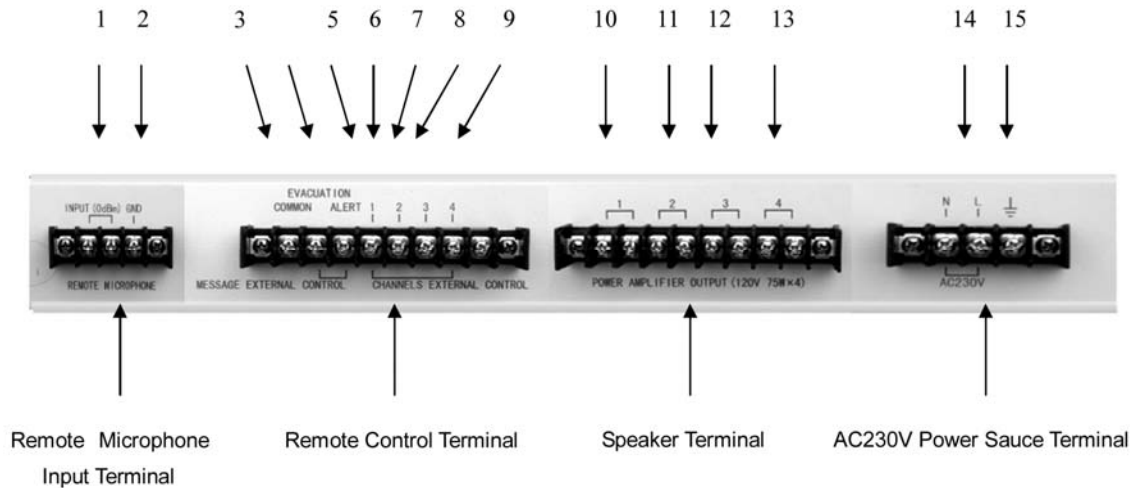

- 1) Remote microphone input line
- 2) Remote microphone shielding line
- 3) Remote control COMMON line
- 4) Evacuation message remote play control line
- 5) Alert message remote play control line
- 6) Broadcast area 1 remote control line
- 7) Broadcast area 2 remote control line
- 8) Broadcast area 3 remote control line
- 9) Broadcast area 4 remote control line
- 10) Broadcast area 1 output line
- 11) Broadcast area 2 output line
- 12) Broadcast area 3 output line
- 13) Broadcast area 4 output line
- 14) Alternating current power supply line
- 15) Protective earth wire

Connecting the Battery

Fix the 2 charging batteries of 24AH, 12V on the bottom of the box with mounting rack provided. Connect the 2 batteries in series with provided connecting wire (red). (Connect the Positive of one battery to the negative of the other one). Connect the green wire marked "BAT+" to Empty positive electrode of the linked batteries. Connect the black one marked "BAT-" to Empty negative electrode, and screw all securing bolts tightly.

CONFIGURING THE PEBS SYSTEM

1. Connect all speakers, EOL units & remote microphone to the main panel
2. Turn on power
3. Press Test button. (panel will perform LED test)
4. Press & hold Test button for 3 seconds. The panel will now search for attached circuits & configure them. The panel will beep & light the LED of a component it has configured (Microphone or speaker circuit)
5. When the configuration is complete, press reset button

Recording an Alert Message.

1. Press test button
2. Press Alert button
3. Press button 2.
4. Pick up Mic & press speak button. Wait for panel to give confirmation beep before speaking. Release button when message complete.
5. Press reset button to exit.

Recording an Evacuate Message.

1. Press test button
2. Press Evacuate button
3. Press button 2.
4. Pick up Mic & press speak button. Wait for panel to give confirmation beep before speaking. Release button when message complete.
5. Press reset button to exit.

Changing the Alert tone *NOT RECOMMENDED*******

1. Press test button
2. Press Alert button

3. Press button 1.
4. Pick up Mic & press speak button. Wait for panel to give confirmation beep before playing new tone. Release button when complete.
5. Press reset button to exit.

Changing the EVACUATE tone *NOT RECOMMENDED*******

1. Press test button
2. Press Evacuate button
3. Press button 1.
4. Pick up Mic & press speak button. Wait for panel to give confirmation beep before playing new tone. Release button when complete.
5. Press reset button to exit.

Recording messages via the panel's microphone does not always give the best results (because of background noise etc)

It is possible to pre-load messages into the panels memory. Ask your distributor about this service. There will be a small charge for this service.

Automatic operation of PEBS

There are 2 points to consider when the PEBS is to be automatically controlled by a fire alarm panel:-

1. Type of connection.

The PEBS supports both a Relay (voltage free) trigger and a "sounder circuit" (voltage) trigger.

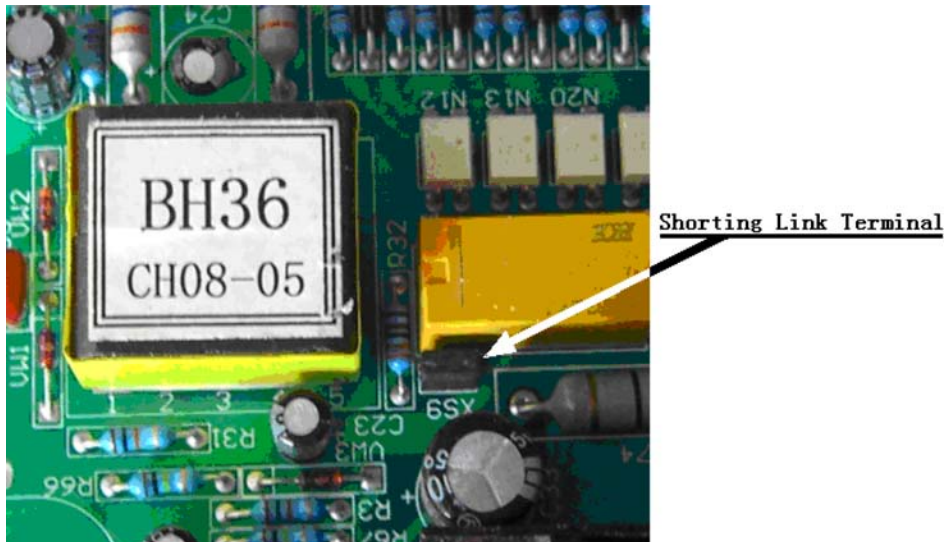

If the shorting link XS9 is open, the trigger will be via Normally Open switch (or relay) contacts.

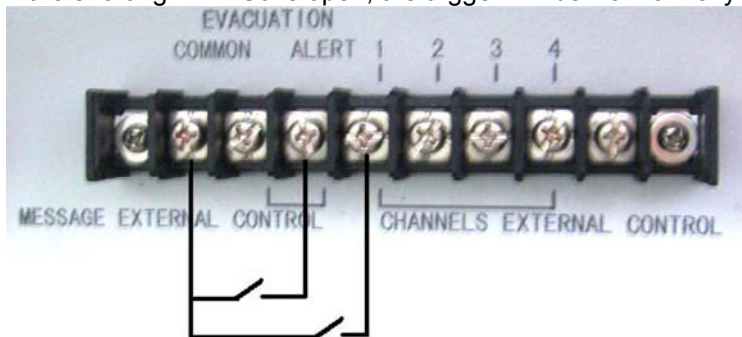

If the shorting link XS9 is closed, the trigger will be via a DC voltage signal (EG a sounder circuit).

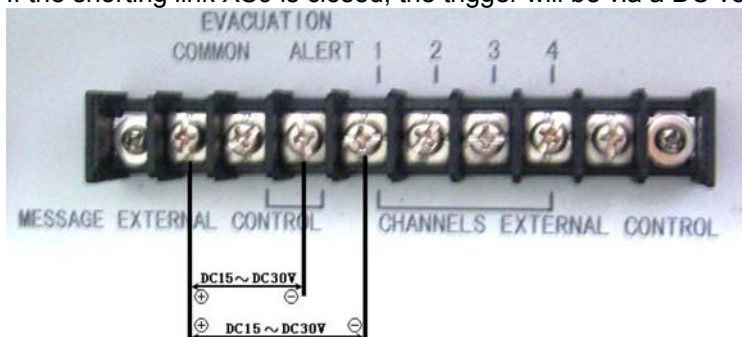

The voltage trigger can be monitored by the Fire alarm panel, so can give a fault if the connection is broken. However care must be taken if linking 2 or more control signals with different states, that the different voltages do not cause a short circuit.

The relay trigger can not be monitored, because it is volt free. But as there is no voltage present, it is possible to use all remote inputs without special precautions.

2. Required operation

Either:-

Leave all channels selected, and connect Fire panel alarm relay (Or I/O relay on addressable system) to the Alert or Evacuate trigger.

OR

Connect Relays to channel select lines & Alert & Evacuate input

Program via fire alarm panel cause & effect which zones will operate, and whether they play alert or evacuate message.

Message format

When a pre-recorded message is broadcast, the PEBS will initially play a siren tone for 3 seconds. It will then pause for 2 seconds. It will then play back the recorded message. After a pause of 3 seconds it will repeat the cycle.

This will continue until the reset key is pressed, or the microphone is activated



NETWORKED SYSTEMS

Since early 2009, it has been possible to link together up to 10 PEBS panels via a 10 way master microphone.

SIMPLIFIED WIRING CONNECTION - NETWORKED PEBS SYSTEM

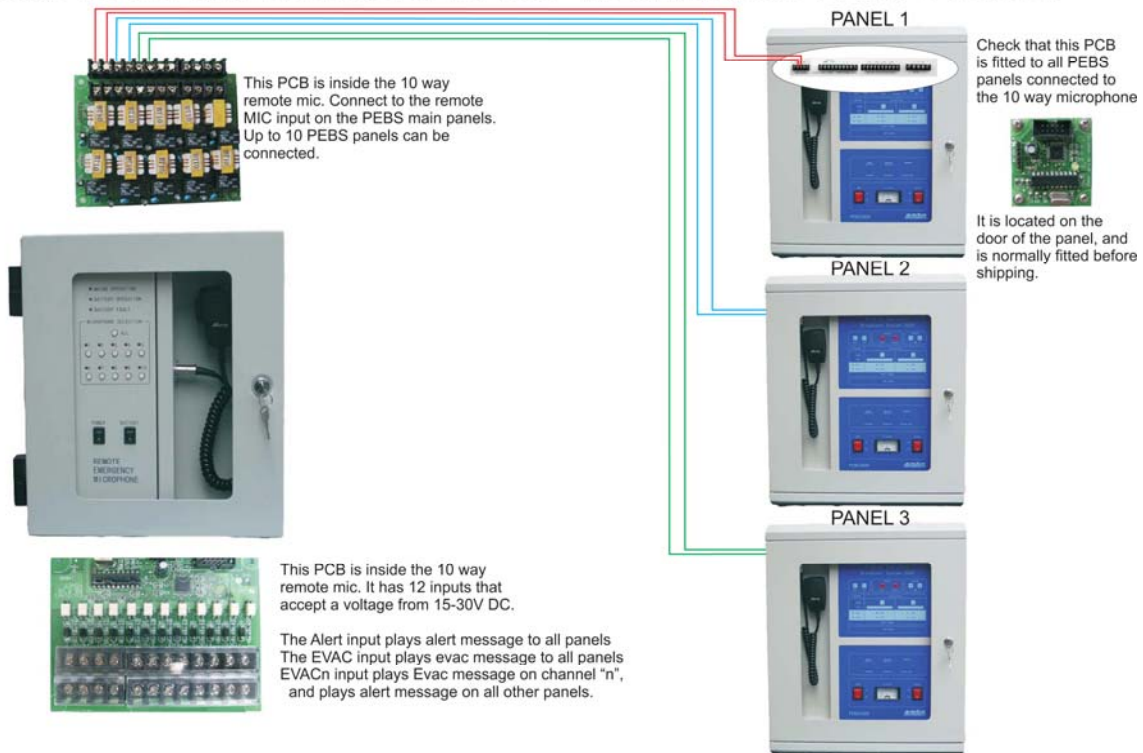

The Master Microphone connects to the remote microphone connector of each PEBS System. Each PEBS panel will need a data decoder PCB fitted. This is usually fitted as the panels are final tested.

The master microphone can now:-

1. Select lines to transmit a live message via the master microphone.
2. Using 24V triggering voltages, the master mic can command panels to:-
 - a. All play back their pre-recorded Alert Message
 - b. the selected unit will play back the pre-recorded EVACUATE message. All remaining 9 units will play back the pre-recorded alert message.
 - c. All play back their pre-recorded EVACUATE Message

Using the Remote microphone operation button and indication light

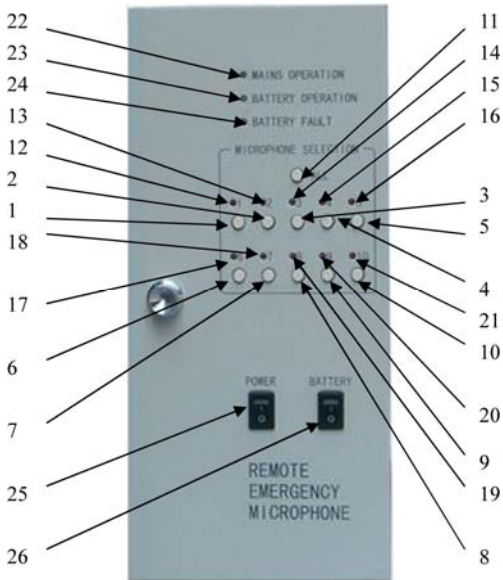

No.	Part name	Function
1	PEBS #1 connecting key	Select No.1 main set, related light working
2	PEBS #2 connecting key	Select No.2 main set, related light working
3	PEBS #3 connecting key	Select No.3 main set, related light working
4	PEBS #4 connecting key	Select No.4 main set, related light working
5	PEBS #5 connecting key	Select No.5 main set, related light working
6	PEBS #6 connecting key	Select No.6 main set, related light working
7	PEBS #7 connecting key	Select No.7 main set, related light working
8	PEBS #8 connecting key	Select No.8 main set, related light working
9	PEBS #9 connecting key	Select No.9 main set, related light working
10	PEBS #10 connecting key	Select No.10 main set, related light working
11	All main set connecting key	Select all main set, related light working
12	PEBS #1 Active LED	No.1 main set connecting selection indication
13	PEBS #2 Active LED	No.2 main set connecting selection indication
14	PEBS #3 Active LED	No.3 main set connecting selection indication
15	PEBS #4 Active LED	No.4 main set connecting selection indication
16	PEBS #5 Active LED	No.5 main set connecting selection indication
17	PEBS #6 Active LED	No.6 main set connecting selection indication
18	PEBS #7 Active LED	No.7 main set connecting selection indication
19	PEBS #8 Active LED	No.8 main set connecting selection indication
20	PEBS #9 Active LED	No.9 main set connecting selection indication
21	PEBS #10 Active LED	No.10 main set connecting selection indication
22	Mains power on LED (green)	AC power supply working indication
23	Back up power on LED (green)	Storage battery working indication
24	Battery Fault (yellow)	Storage battery low voltage indication
25	Main power supply switch	Control the AC input
26	Back up power supply switch	Control the Storage battery input

Press the relevant PEBS SYSTEM select button so select which PEBS panels to broadcast to. (EG press 1,3 & 7 to use the microphone to broadcast on panels 1,3 &7). Press the microphone to begin broadcast. To deselect a system, press that system's number again. Press ALL to select to broadcast to all systems connected.

Product Specifications

(1) PEBS2000 Main Unit

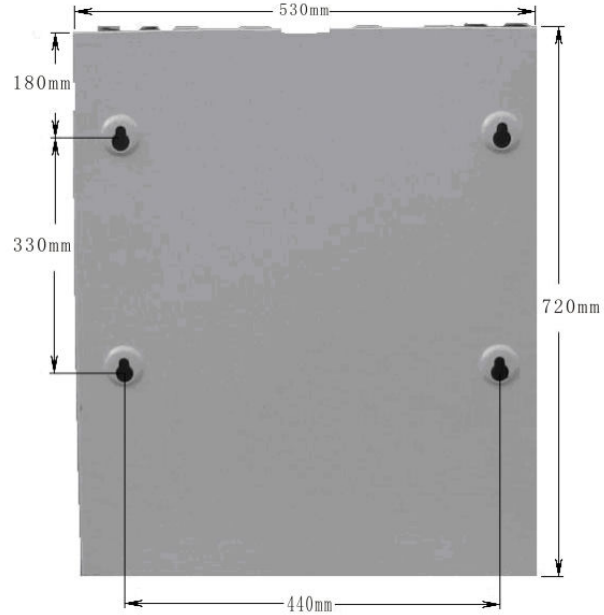

Item	Parameter
Input Sensitivity of Local Microphone	1mv
Input Sensitivity of Remote Microphone	300 mv
Signal-to Noise Ratio	≥55dB
Rated Output Power	300W
Voltage Regulation	≤2dB
Frequency Characteristics	63Hz-10kHz ≤1dB
Harmonic Distortion	≤5%
Output Characteristics	120V (Constant Voltage)
Total Number of Broadcast Areas	4-channel
Message Storage Time	2 minutes
Monitoring Output Power	≥0.25W
Operation Range of Mains	AC195V~253V 50□60Hz
Low Voltage Alert Point of Mains	AC176V~187V
Range of Mains Low Voltage Protection	AC170V
Operation Range of Standby Power Supply	DC20V□28V
Low Voltage Alert Point of Standby Power Supply	DC 21.5V±1V
Range of Standby Power Supply Low Voltage Protection	-1.6V (low voltage alert point of standby power supply)
Charging Range of Standby Power Supply	DC 18V

Dimension: 530mm×230mm× 720mm (L×W×H)

Net Weight: 34Kg

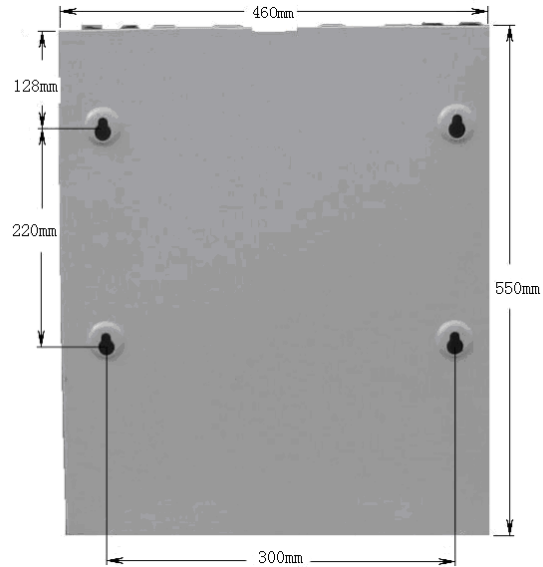
(2) PEBS1000 Main Unit

Item	Parameter
Input Sensitivity of Local Microphone	1mV
Input Sensitivity of Remote Microphone	300 mV
Signal-to Noise Ratio	≥55dB
Rated Output Power	300W
Voltage Regulation	≤2dB
Frequency Characteristics	63Hz ~ 10kHz ≤1dB
Harmonic Distortion	≤5%
Output Characteristics	120V (Constant Voltage)
Total Number of Broadcast Areas	2-channel
Message Storage Time	2 minutes
Monitoring Output Power	≥0.25W
Operation Range of Mains	AC195V~253V 50 / 60Hz
Low Voltage Alert Point of Mains	AC176V~187V
Range of Mains Low Voltage Protection	< AC170V
Operation Range of Standby Power Supply	DC20V ~ 28V
Low Voltage Alert Point of Standby Power	DC 21.5V±1V
Range of Standby Power Supply Low Voltage Protection	-1.6V
Charging Range of Standby Power Supply	> DC 18V

Dimension: 460mm×210mm× 5500mm (L×W×H)

Net Weight: 20Kg

BOTH UNITS:-

Operating Environment

Temperature: 0°C ~ 40°C

Moisture: ≤90%RH

Air Pressure: 86~106kPa

(3) Broadcast Line Terminal Device (ESEOL)

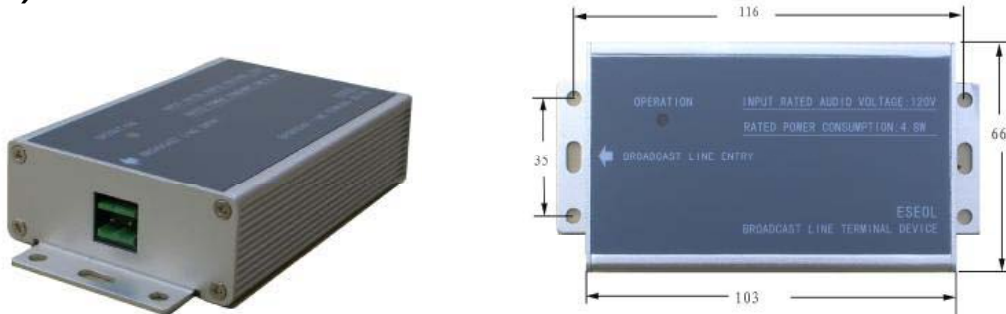

Item	Parameter
Range of Operation Voltage	120V (Constant Voltage)
Maximum Power Consumption	120mW

Dimension: 103mm×66mm×27mm (L×W×H)

Net Weight: 0.1Kg

(4) Remote Microphone (RMM2000)



Item	Parameter
Range of Operation Voltage	DC20V-28V
Maximum Power Consumption	120mw
Input Sensitivity of Microphone	1mv
Signal Gain	50dB
Frequency Characteristics	300Hz-3400Hz
Longest Distance of Wiring	1000 meters

(5) 10 Way Master Microphone



Item	Parameter
Range of Operation Voltage	DC20V ~ 28V
Maximum Power Consumption	120mw
Input Sensitivity of Microphone	1mv
Signal Gain	> 50Db
Frequency Characteristics	300Hz ~ 3400Hz
Longest Distance of Wiring	1000 meters

Dimension: 330mm×390mm×120mm (L×W×H)

Net Weight: 7.3Kg

(6) Broadcast Speaker (CS3)



Item	Parameter
Input Audio Voltage	120V (Constant Voltage)
Rated Input Power	3W
Frequency Response	120Hz ~ 11kHz
Sensitivity	90dB±3dB

Dimension: Diameter × Height φ230mm×125mm

Net Weight: 1.3Kg

(7) Network data decode module (GXE0-2050-D)

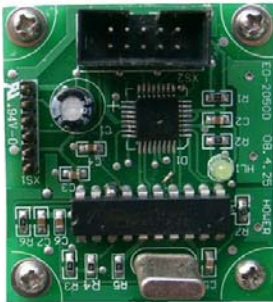

When using this module, please use 10 WAY RIBBON CABLE to connect XS2 and the XS2 of E0-2050B (2 channel) or E0-2300B (4 channel) circuit boards

(8) Remote control module PCB (GXE0-224E-C)

This PCB is part of the 10 way master microphone.

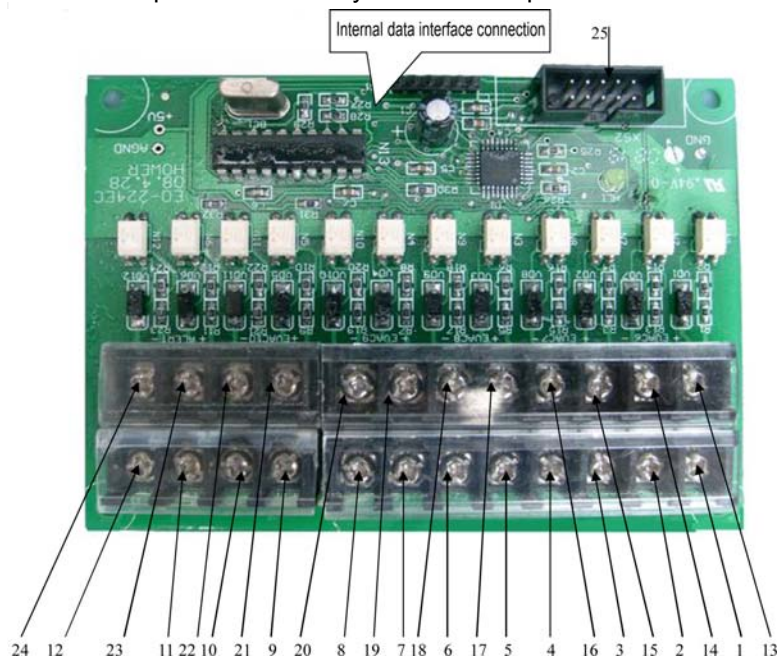

No.	Description	No.	Description
1	EVAC +	2	EVAC -
3	EVAC 1 +	4	EVAC 1 -
5	EVAC 2 +	6	EVAC 2 -
7	EVAC 3 +	8	EVAC 3 -
9	EVAC 4 +	10	EVAC 4 -
11	EVAC 5 +	12	EVAC 5 -
13	EVAC 6 +	14	EVAC 6 -
15	EVAC 7 +	16	EVAC 7 -
17	EVAC 8 +	18	EVAC 8 -
19	EVAC 9 +	20	EVAC 9 -
21	EVAC 10 +	22	EVAC 10 -
23	ALERT +	24	ALERT -
25	CONNECTOR TO 224EB CIRCUIT BOARD		

The Remote Control Module works as follows:-

If you apply 15~30VDC to Alert Terminals, all 10 PEBS systems connected will play alert message.

If you apply 15~30VDC to Evac Terminals, all 10 PEBS systems connected will play evac message.

If you apply 15~30VDC to Evac1 Terminals, PEBS 1 will play Evac message, all other PEBS will play alert message.

If you apply 15~30VDC to Evac2 Terminals, PEBS 2 will play Evac message, all other PEBS will play alert message.

ETC

If you apply 15~30VDC to Evac1 AND Evac2 Terminals, PEBS 1 & 2 will play Evac message, all other PEBS will play alert message.

(9) Remote microphone terminal

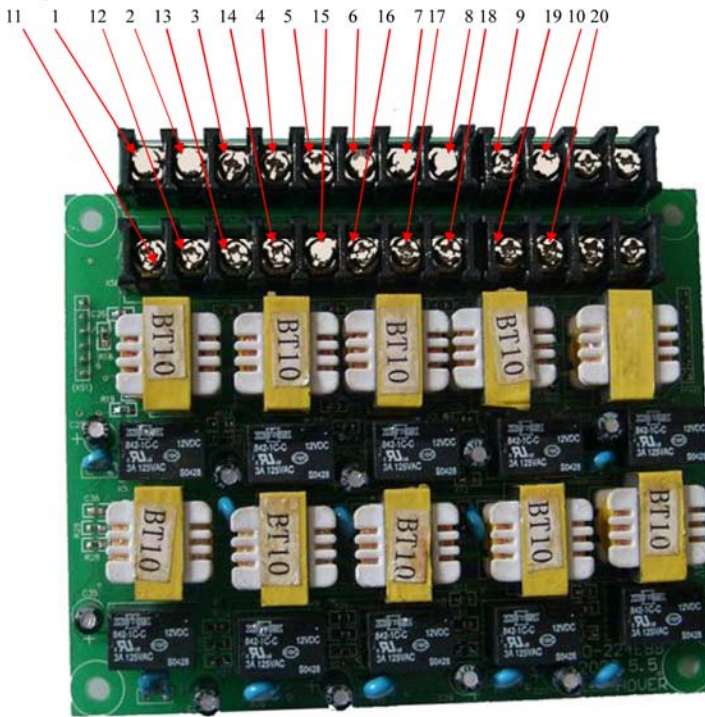

No.	Description	Connect to	No.	Description	Connect to
1	LIN1A	PEBS 1 remote mic connection A	2	LIN1B	PEBS 1 remote mic connection B
3	LIN2A	PEBS 2 remote mic connection A	4	LIN2B	PEBS 2 remote mic connection B
5	LIN3A	PEBS 3 remote mic connection A	6	LIN3B	PEBS 3 remote mic connection B
7	LIN4A	PEBS 4 remote mic connection A	8	LIN4B	PEBS 4 remote mic connection B
9	LIN5A	PEBS 5 remote mic connection A	10	LIN5B	PEBS 5 remote mic connection B
11	LIN6A	PEBS 6 remote mic connection A	12	LIN6B	PEBS 6 remote mic connection B
13	LIN7A	PEBS 7 remote mic connection A	14	LIN7B	PEBS 7 remote mic connection B
15	LIN8A	PEBS 8 remote mic connection A	16	LIN8B	PEBS 8 remote mic connection B
17	LIN9A	PEBS 9 remote mic connection A	18	LIN9B	PEBS 9 remote mic connection B
19	LIN10A	PEBS 10 remote mic connection A	20	LIN10B	PEBS 10 remote mic connection B

Terminals LINnA and LINnB connect to the Remote Mic Input of PEBS panel No. "n" (n=1~10)

12. Fault Analysis and Rectification

In the event of a fault condition, the PEBS will light the appropriate fault LED & play a fault tone on it's internal speaker. Press any key except monitoring volume key to cancel fault alarm sound. The fault indicator LEDs will stay on until the fault has been rectified.

Symptom	Analysis	Remedy
Indicator does not light	Is there AC230V input voltage? Is the switch of mains on? Check the safety Fuse Check the connection of electrode of DC24V power supply (batteries)	Link the power supply. Turn on the switch Change safety Fuse Reconnect
Overload indicator lights	There is overloading of power amplifier. There is serious circuit fault.	Decrease the number of speakers and alarms. Check and remove the circuit fault
Microphone does not work properly	Has the system been configured? Are the wires in good condition?	Configure the system Check and remove the fault.
Broadcast area can not put through	Has the system been configured? Are the wires in good condition? Is the end of line connected & working?	Configure the system Check and remove the fault. Fit or replace EOL as necessary
Mains low voltage indicator lights	The AC input voltage is too low.	Increase the AC input voltage.
Standby power supply low voltage lights	The battery voltage is too low.	Charge the battery.
Standby power supply fault indicator lights	Open circuit or short circuit of the connection of battery.	Check and remove the circuit fault.

13. Storage Environment Requirements

Temperature: -10~55°C
Relative Humidity: 15%~90%
Air Pressure: 86~106kPa
Storage Duration: 2 years

Please energize power supply at least 4 hours to continue storage when the equipment has been stored for more than 1 year.