

# Premier AD

ANALOGUE ADDRESSABLE  
FIRE ALARM CONTROL PANEL



## INSTALLATION MANUAL

## CONTENTS

1.	PREMIER AD OVERVIEW.....	3
	1.1 SETTING THE DEVICE ADDRESS (DETECTORS, CALL POINTS & SOUNDERS)	
2.	LIST OF COMPATIBLE EQUIPMENT.....	4
	2.1 SUPPORTED SOUNDER TYPES & THEIR APPLICATIONS	
3.	INTRODUCTION.....	5
	3.1 THE PCBs	
	3.2 USING THIS MANUAL	
	3.3 ABOUT THE PREMIER AD FACP & INTEGRAL PSE	
	3.4 DESIGNING THE SYSTEM	
	3.5 EQUIPMENT GUARANTEE	
4.	FIRST FIX GUIDELINES.....	6
	4.1 RECOMMENDED CABLE TYPES AND THEIR LIMITATIONS	
	4.2 MAINS WIRING RECOMMENDATIONS	
	4.3 SOUNDER CIRCUIT WIRING DIAGRAM	
	4.4 ADDRESSABLE LOOP WIRING DIAGRAM	
	4.5 SPECIFIC DEVICE WIRING INSTRUCTIONS	
	4.6 AUXILIARY INPUT WIRING EXAMPLES	
	4.7 AUXILIARY OUTPUT WIRING (VOLTAGE FREE CHANGEOVER CONTACTS)	
5.	MOUNTING THE FIRE ALARM PANEL.....	11
	5.1 PLANNING CABLE ENTRY	
	5.2 FIXING THE BACKBOX TO THE WALL	
6.	CONNECTING MAINS & BATTERY POWER.....	12
	6.1 CONNECTING MAINS POWER	
	6.2 CONNECTING THE BATTERIES	
7.	FIELD DEVICE TERMINATION.....	13
	7.1 TERMINATING THE DETECTION AND ALARM (SOUNDER) CIRCUITS	
	7.2 AUXILIARY INPUT AND OUTPUT TERMINATIONS	
8.	DESIGNING THE SYSTEM & CONFIGURING THE FACP.....	14
	8.1 LOOP CONTENTS FAULT FINDING	
	8.2 ADDRESS - ZONE TABLE	
9.	ZONE DISABLEMENT.....	18
	9.1 WHY USE ZONE DISABLEMENT	
	9.2 TO PROGRAM A ZONE (OR SOUNDERS) AS DISABLED	
10.	TEST MODE.....	19
	10.1 WHY USE TEST MODE	
	10.2 TO PROGRAM ZONE IN TEST	
	10.3 TO PROGRAM SOUNDER CIRCUITS IN TEST MODE	
11.	GENERAL FAULT FINDING.....	20
	11.1 COMMON FAULT	
	11.2 ZONE FAULTS	
	11.3 SUPPLY FAULT	
	11.4 EARTH FAULTS	
	11.5 DOUBLE ADDRESS	
	11.6 SYSTEM FAULT	
	11.7 PRE-ALARM	
	11.8 SOUNDER FAULTS	
	11.9 LOOP WIRING FAULTS	
12.	STANDBY BATTERY REQUIREMENTS .....	23
	12.1 STANDBY BATTERY CALCULATION	
13.	PCB TERMINATION CONNECTIONS.....	25
	13.1 CONNECTIONS	
	13.2 FUSES	
14.	CONTROL PANEL ELECTRICAL SPECIFICATIONS.....	26
	14.1 ENCLOSURE SPECIFICATIONS	
	14.2 ELECTRICAL SPECIFICATIONS	

## 1. PREMIER AD OVERVIEW

The Premier AD is a 2-loop analogue addressable fire alarm control panel designed to EN54 part 2 & 4. It has 2 addressable loops, each capable of having 126 devices, and also 4 independently operating sounder circuits.

It has been designed to give the advantages of an addressable system, with the simplicity of a conventional system. To help achieve this, the Premier AD uses its LEDs as the Primary source of information, so in most cases, there is no reason to look at the screen, or access any menus. The screen is simply there to identify loop device fault locations, and to help in setting up the panel.

To simplify commissioning further, there is no zone allocation programming. Instead each loop is split into 8 zones, and each device is assigned to a zone by the address set with its 8 way dip switch.

Address 1-16	Zone 1 (Zone 9 on loop 2)
Address 17-32	Zone 2 (Zone 10 on loop 2)
Address 33-48	Zone 3 (Zone 11 on loop 2)
Address 49-64	Zone 4 (Zone 12 on loop 2)
Address 65-80	Zone 5 (Zone 13 on loop 2)
Address 81-96	Zone 6 (Zone 14 on loop 2)
Address 97-112	Zone 7 (Zone 15 on loop 2)
Address 113-126	Zone 8 (Zone 16 on loop 2)

The Premier AD has 4 sounder circuits, which are always configured as common sounders. They will activate with an alarm from any zone.

The loop outputs (loop powered sounders, & sounder circuit controllers) can be set up as zonal, or common.

If the sounder is in a zone that contains a detector or input module, then that sounder will be zonal, and will only activate with an alarm in that zone.

If the sounder is in a zone that only contains output devices, then it will be common, and will activate with any alarm.

The exception to this rule is a priority Call Point, which will start all sounders, even if they are set up as zonal.

### 1.1 SETTING THE DEVICE ADDRESS (DETECTORS, CALL POINTS & SOUNDERS)

The device address is set with a dip switch on the rear of the device.

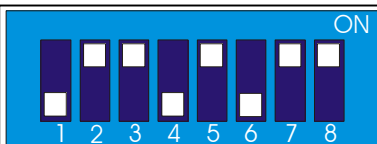

The address setting is binary, with the **ON** position being binary **0**, and the **OFF** position being binary **1**. Switch 8 is not used for setting the address, but sometimes has a device specific function. (check instructions that came with the device)

If you are not familiar with binary, check the table on page 17, or use the following rule:

Switch 7 off = add 64,  
 Switch 6 off = add 32,  
 Switch 5 off = add 16,  
 Switch 4 off = add 8,  
 Switch 3 off = add 4,  
 Switch 2 off = add 2,  
 Switch 1 off = add 1.

The example shown would be:  
 switches 6, 4 & 1  
 =32 + 8 + 1 = Address 41

#### LIMITATIONS OF PRESET ZONE ALLOCATION

The main disadvantage of this method of zone allocation is the maximum zone capacity of 16 devices. If a zone has more than 16 devices it will need to be split into smaller zones.

Similarly, a zone with only one device would leave 15 empty addresses on that zone.

This will not cause a problem if it is considered at the system design stage.

## 2. LIST OF COMPATIBLE EQUIPMENT

Stock No	Product Code	Device
37-150	PR-AD	Premier AD Fire Alarm Panel
37-155	PREP-AD	Premier AD Repeater
80-110	FEAI2000	Fyreye Addressable Ionisation Detector
80-120	FEAO2000	Fyreye Addressable Optical Detector
80-130	FEAH2000	Fyreye Addressable Heat Detector
80-131	FEAHH2000	Fyreye Addressable High Temperature Heat Detector
80-140	FEAOH2000	Fyreye Addressable Multi-Point Detector
80-150	FECO2000	Fyreye Addressable Carbon Monoxide Detector
80-050	FE-CB	Fyreye Common Base
80-080	FEA-RB	Fyreye Addressable Relay Base
80-090	FE-IB	Fyreye Addressable Loop Isolator Base
80-100	FEA-SB	Fyreye Addressable Sounder Base
80-101	FEA-ISB	Fyreye Addressable Isolator Sounder Base
43-001	ZT-MCP/AD	Zeta Addressable Call Point
43-022	ZT-MCP/AD/WP	Zeta Weatherproof Addressable Call Point
48-100	ZIU	Zeta Input Unit
48-105	ZIOU	Zeta Input Output Unit
48-110	ZSCC	Zeta Sounder Control Module
48-115	ZT-ZM	Zeta Zone Monitor Unit
42-007	ZAMT	Zeta Addressable Maxitone Sounder
42-008	ZAMD	Zeta Addressable Miditytone Sounder
42-030	ZAST	Zeta Addressable Securetone Sounder
48-020	ZTA/LE2	Zeta Addressable Remote Led Indicator
47-055	ZTA-FR50	Fyreye Addressable Reflective Beam Detector 50m
47-056	ZTA-FR100	Fyreye Addressable Reflective Beam Detector 100m
47-110	FE+50/AD	Fyreye Plus Addressable Aspiration Detector
42-001	ZMT/8	Zeta Conventional Maxitone Sounder
42-002	ZMD/8	Zeta Conventional Miditytone Sounder
42-004	ZST/8	Zeta Conventional Securetone Sounder
42-005	ZIDC/10R	Zeta Conventional Megatone Sounder
42-011	ZFL2RR	Zeta Conventional Flasher
42-013	ZLT/8RR	Zeta Conventional Flasher Sounder
41-003	ZTB6B/24	Zeta Conventional 6" Bells
41-005	ZTB8B	Zeta Conventional 8" Bells

### 2.1 SUPPORTED SOUNDER TYPES & THEIR APPLICATIONS

The Premier AD supports 4 general sounder types; conventional, addressable, addressable sounder controller, and associated sounders. All types have advantages & disadvantages.

Sounder type	Advantage	Disadvantage
Conventional	Wide range of devices Devices tend to be cheaper. Immediate start / stop No quiescent current	Needs extra cabling Always configured as common sounders
Addressable	No Extra Cabling Sounders can be configured as zonal	Tends to be more expensive Maximum 32 per loop for quick start/stop Quiescent current high Uses device address.
Associated (sounder- base)	No Extra Cabling Doesn't occupy Device Address Can have more than 32 per loop	4-8 second start & stop time. Always configured as common sounders Needs detector present to operate. Does not operate during sounder test mode
Addressable Sounder Circuit Controller	Wide range of devices Devices tend to be cheaper. Can add many sounder circuits to system Sounder circuit can be set as zonal	Needs Extra Cabling. Needs External PSU Maximum 32 per loop for quick start/stop Quiescent current high Uses device address.

### 3.INTRODUCTION

#### **THIS FIRE ALARM CONTROL PANEL IS CLASS 1 EQUIPMENT AND MUST BE EARTHED**

This equipment must be installed and maintained by a qualified and technically experienced person.

#### 3.1 HANDLING THE PCBs

If the PCBs are to be removed to ease fitting the enclosure and cables, care must be taken to avoid damage by static.

The best method is to wear an earth strap, but touching any earth point (eg building plumbing) will help to discharge any static. Hold PCBs by their sides, avoiding contact with any components. Always handle PCBs by their sides and avoid touching the legs of any components. Keep the PCBs away from damp dirty areas, e.g. in a small cardboard box.

#### 3.2 USING THIS MANUAL

This manual explains, in a step-by-step manner, the procedure for the installation of the **Premier AD** Range of Fire Alarm Control Panels. For full operational and maintenance information, please refer to document GLT.MAN-106 (USER MANUAL, MAINTENANCE GUIDE & LOG BOOK). It also contains a System set-up table, and Installation Certificate, that must be completed by the Commissioning Engineer prior to system handover.

**Unlike the User Manual, this Installation Manual must not be left accessible to the User.**

#### 3.3 ABOUT THE PREMIER AD FIRE ALARM CONTROL PANEL & INTEGRAL PSE

- The PREMIER AD Fire alarm control panel is a two loop analogue addressable Fire Alarm Control Panel, with the loops split into 16 Zones.
- It has 4 sounder output circuits each capable of supplying 250mA.
- It has a set of fire relay contacts (voltage free) rated at 1A SELV.
- It has a set of fault relay contacts (voltage free) rated at 1A SELV. This relay is normally powered to allow a fault output in the case of total power failure.
- It has a class change connection to allow remote activation of the sounders. (not required by EN54-2)
- It has the ability to disable any zone or any of the sounder circuits.
- It has a one man test mode, which resets the zone in test after 8 seconds.(EN54 option with requirements)
- It has a maximum battery capacity of 7 Ah.

- It will operate in ambient temperatures of -5 to 40°C
- It will operate in a relative humidity of up to 93% (non condensing)
- It will withstand vibrations between 5 & 150 Hz
- It has a maximum capacity of 32 devices per zone
- The PSE is linear, with a 1.5A output at system voltage (18-32V)
- The mains supply is filtered before entering the transformer.
- The charger & battery are both fused at 2.5A (time delay)
- The PSE will draw a maximum of 25uA from the battery in the event of mains failure. (the FACP will continue to take around 60mA)
- The FACP & PSE should be maintained as described in section 3 of the User Manual, Maintenance Guide & Log Book.

#### 3.4 DESIGNING THE SYSTEM

This manual is not designed to teach Fire Alarm System design. It is assumed that the System has been designed by a competent person, and that the installer has an understanding of Fire Alarm System components and their use.

We strongly recommend consultation with a suitably qualified, competent person regarding the design of the Fire Alarm System. The System must be commissioned and serviced in accordance with our instructions and the relevant National Standards. Contact the Fire Officer concerned with the property at an early stage in case he has any special requirements.

If in doubt, read BS 5839: Pt 1: 2002 "Fire Detection and Alarm Systems for buildings (Code of Practice for System Design, Installation, commissioning and maintenance)" available from the BSI, or at your local reference library.

#### 3.5 EQUIPMENT GUARANTEE

If this equipment is not fitted and commissioned according to our guidelines, and the relevant National Standards, by an approved and competent person or organisation, the warrantee may become void.

**4. FIRST FIX**

**All wiring must be installed to meet BS5839: Pt1: 2002 and BS 7671 (Wiring Regs) standards. Other National standards of fire alarm system installation should be adhered to where applicable.**

**4.1 RECOMMENDED CABLE TYPES AND THEIR LIMITATIONS**

Screened cables should be used throughout the installation to help shield the Panel from outside interference and ensure EMC compatibility.

The two categories of cable according to BS5839: Pt1: 2002, Clause 26 “Fire Detection and Alarm Systems for Buildings (Code of Practice for System Design, Installation and Servicing)” are:

- Standard fire resisting cable – to PH30 classification of EN 50200**
- Enhanced fire resisting cable – to PH120 classification of EN 50200**
- (Note that all cables should be at least 1mm<sup>2</sup> cross section)**

On the Premier AD Panel the general recommendation would be to use standard fire resistant cable, such as Firetuff™, FP200 or an equivalent. These cables are screened, and will provide good ECM shielding when properly grounded at the panel. Certain system specifications may demand the use of a particular type of cable and due regard should be paid to this fact.

Depending on the environment, the cables may need mechanical protection (such as a conduit).

**4.2 MAINS WIRING RECOMMENDATIONS**

The Mains supply to the FACP is fixed wiring, using **Fire resisting** 3-core cable (Between 1 mm<sup>2</sup> and 2.5mm<sup>2</sup>) or a suitable 3-conductor system, fed from an isolating double pole switch fused spur, fused at 3A. **IT SHOULD NOT BE CONNECTED THROUGH AN RCD.** This should be secure from unauthorised operation and be marked ‘FIRE ALARM: DO NOT SWITCH OFF’. The supply must be exclusive to the Fire Panel. **MAKE SURE ANY SPARE ENTRY HOLES ARE COVERED WITH THE GROMMETS PROVIDED**

For information on how to connect Mains to the Panel’s Power Supply PCB, see page 8. Also refer to rating information on the mains cover inside the FACP

**4.3 CONVENTIONAL SOUNDER CIRCUIT WIRING DIAGRAM**

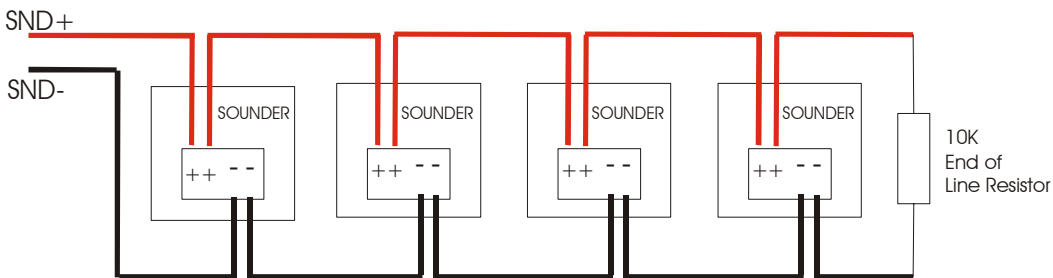

Note: If non-polarised alarm devices (eg some types of old mechanical bell, or a relay) are used, then a diode will have to be placed in line with the device to enable fault monitoring. They may also need a back EMF protection diode. (symptoms: Chattering sounder relays that don’t turn off).

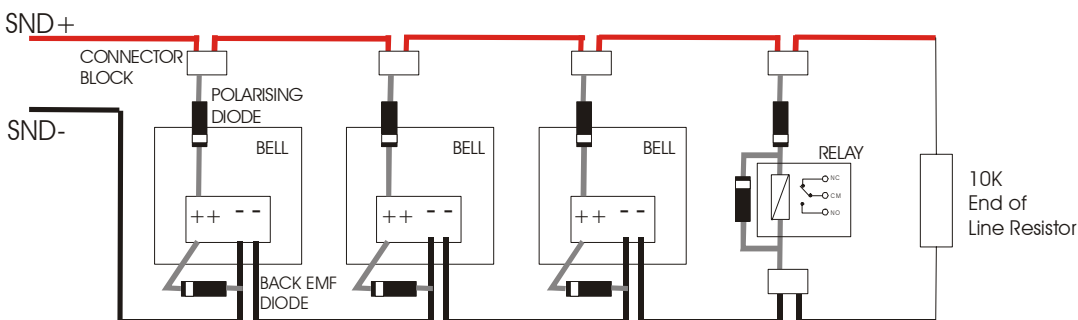

#### 4.4 ADDRESSABLE LOOP WIRING DIAGRAM

The Premier AD comes with two addressable loops. Addressable detectors, addressable call points, addressable loop powered sounders and several other interface units can be connected to these loops. A MAXIMUM OF 126 DEVICES CAN BE CONNECTED TO EACH LOOP.

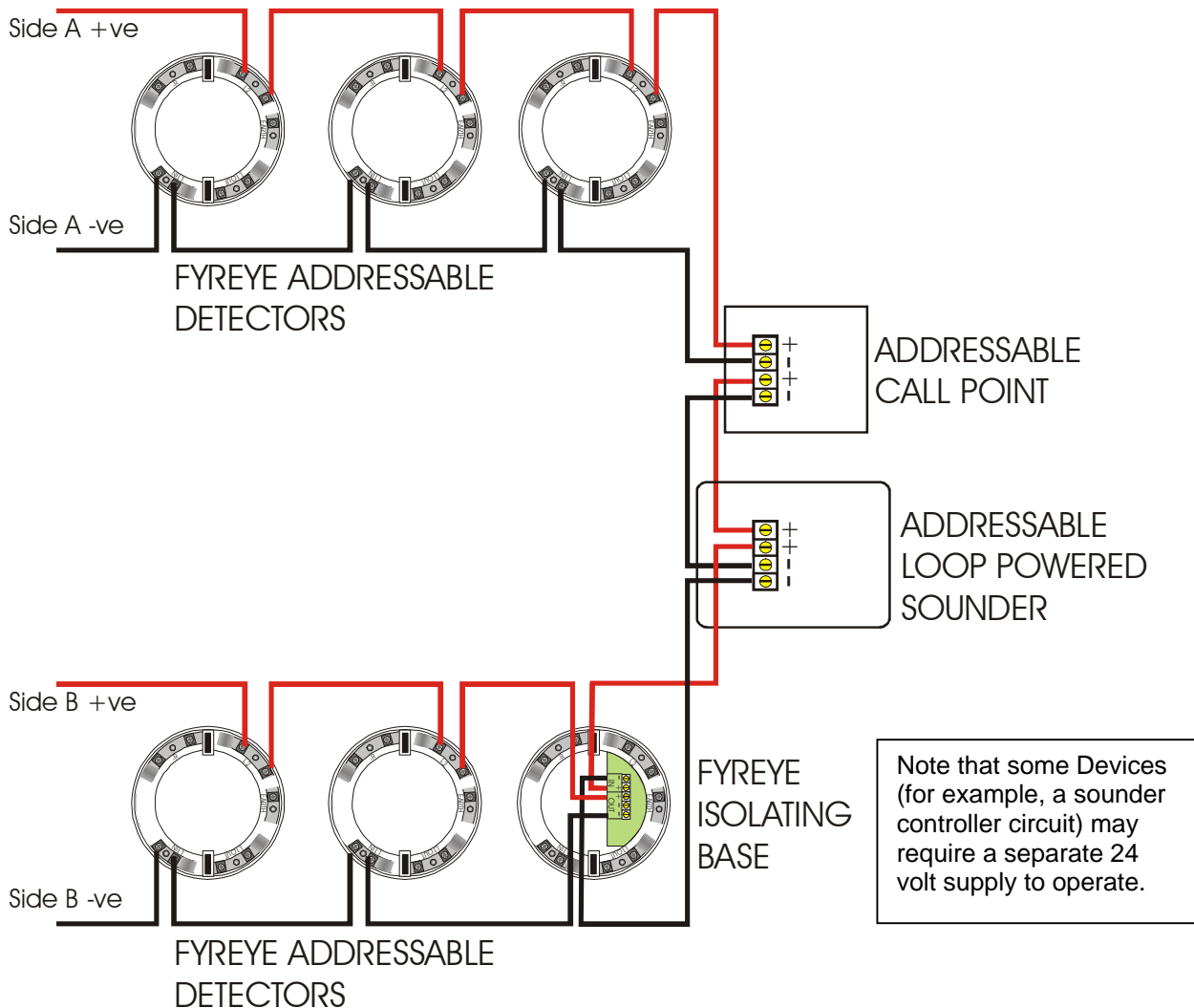

A maximum of 32 loop-powered addressable sounders are permitted on the loop. There is no limit (loop load permitting) to the number of sounder bases that can be connected to a loop. On the Premier AD Panel, all Sounder Bases are always configured as common sounders.

Short circuit isolators should be used to prevent losing the whole loop in the event of a single short circuit fault. They should be fitted to each zone boundary, such that any short circuit will only affect the devices in 1 zone.

The termination of each detection circuit must be as indicated on the main PCB (See page 15). The Earthing of the cable screens should be as shown on page 9

##### Pre-Commissioning Cable Checks

1. +ve in to +ve out less than 24 ohms
2. -ve in to -ve out less than 24 ohms (may need to temporarily disable isolators to measure)
3. +ve to -ve greater than 500k ohm
4. +ve to Earth greater than 1M ohm.
5. -ve to Earth greater than 1M ohm.
6. +ve to -ve less than 50 mV pickup (on AC & DC scales)

**SPECIFIC DEVICE WIRING INSTRUCTIONS:**

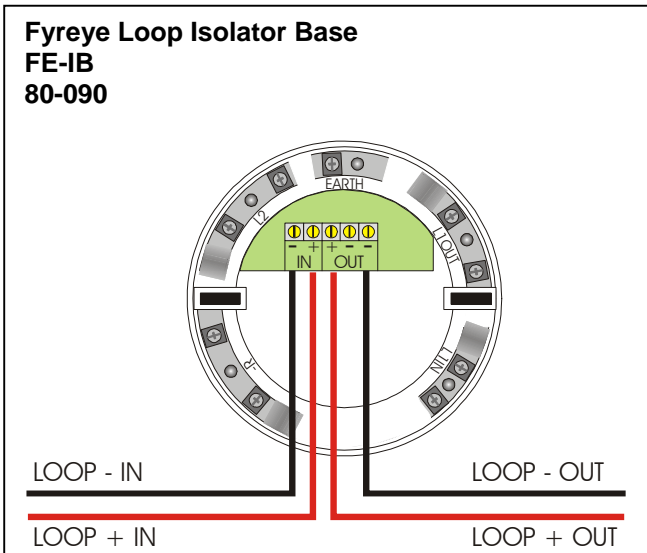
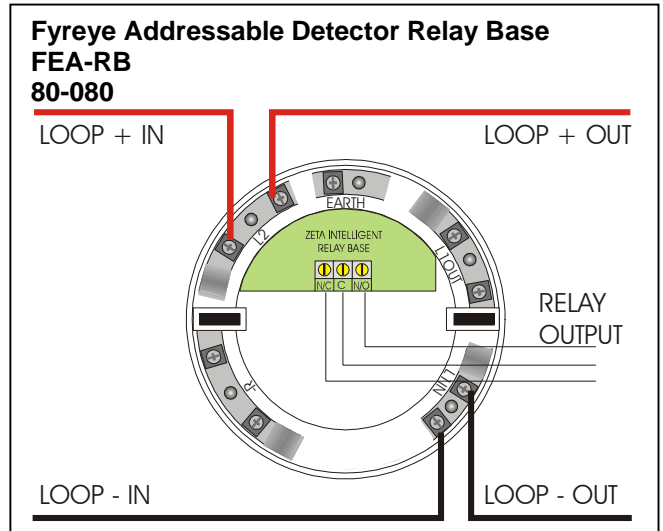
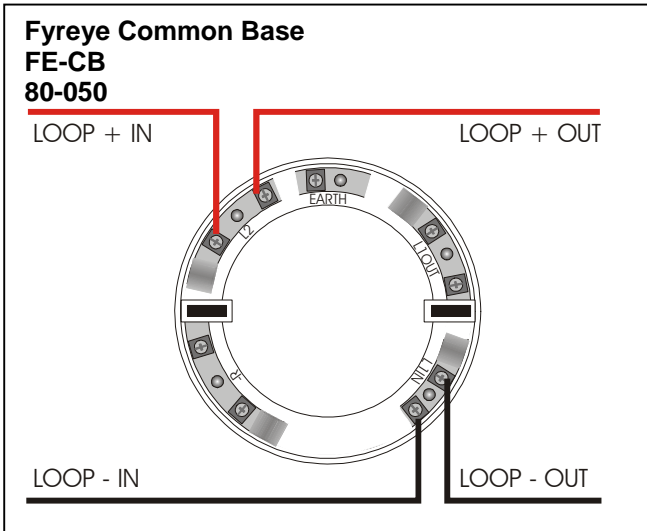

Note that on the Fyreye Loop Isolator Base, the loop wiring connects to the terminal block on the PCB and NOT to the Base Spring Screws.

The terminals are marked + & - in, and +,- & - out.

The second -ve contact can be used during commissioning to check the loop integrity.

(Connect the -in to the spare - out. Repeat for all isolators. Measure -ve line resistance with a DVM. Return the -in cable to its original terminal block.)

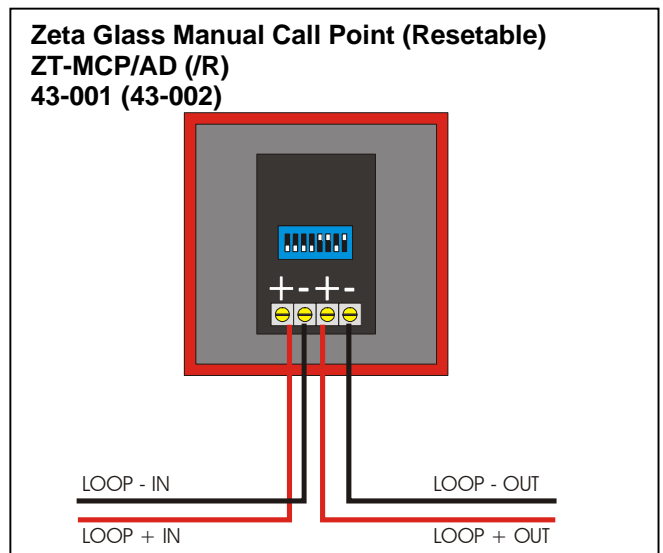
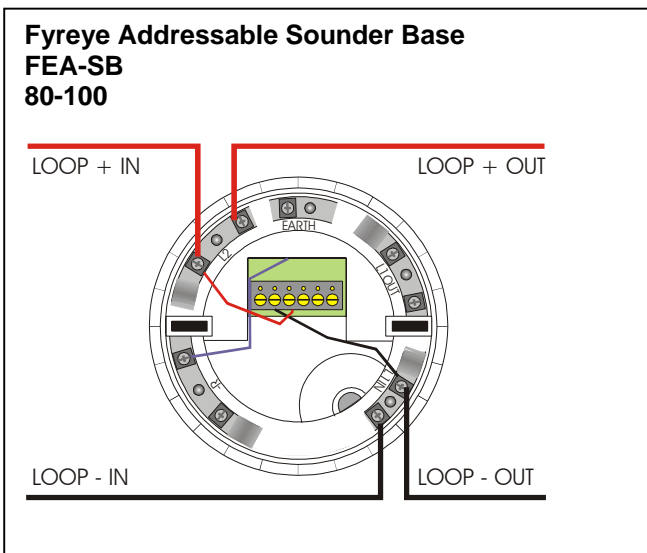



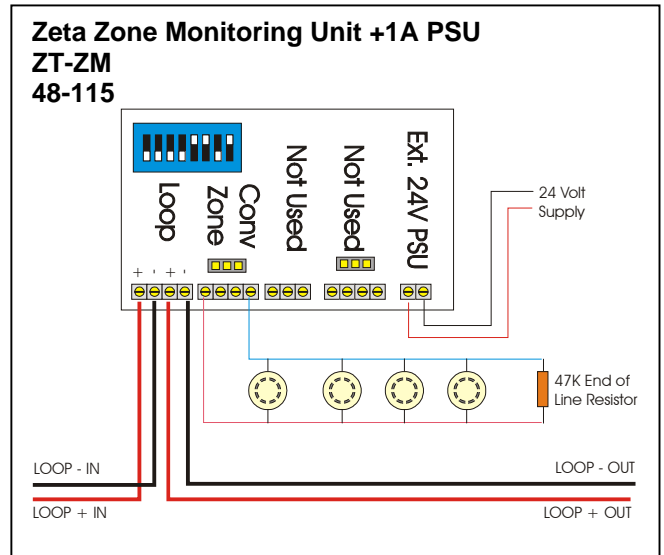
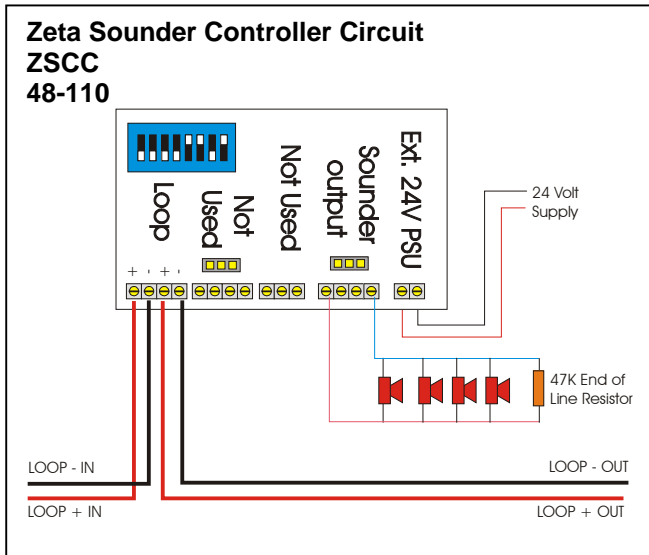
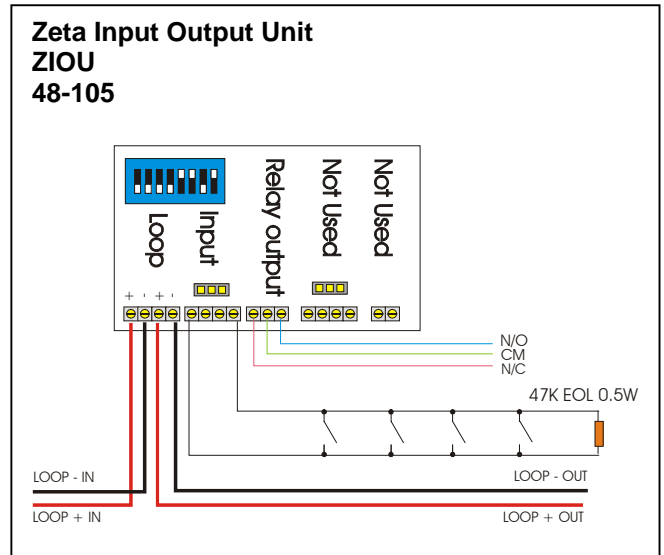
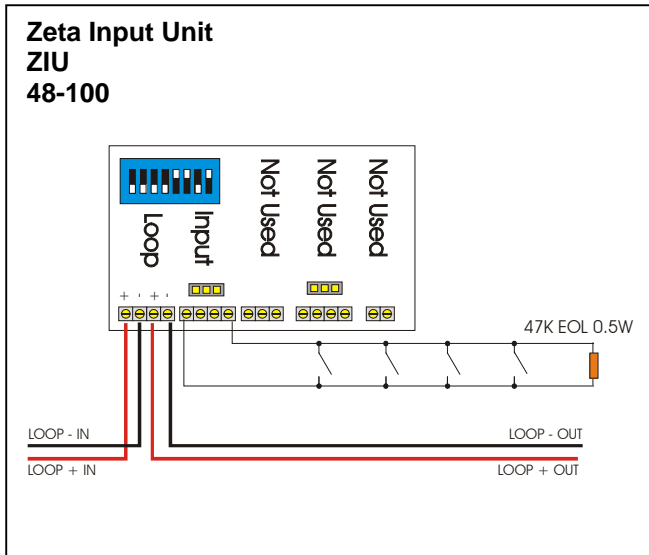

### 4.6 AUXILIARY INPUT WIRING EXAMPLES

There is one non-latching auxiliary input connection on the Fire Alarm Panel.

**Class Change Input (CC):** This will energise all alarm outputs continuously when the CC terminals are shorted together. (This includes the 4 conventional sounder outputs & any loop powered sounders.)

*Typical auxiliary input wiring options*

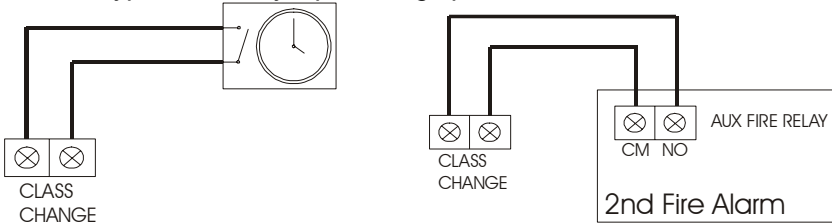

The termination for the above inputs must be as indicated on the main PCB (See page 15). The Earthing of the cable screens should be as shown on page 9.

### 4.7 AUXILIARY OUTPUT WIRING (VOLTAGE FREE CHANGEOVER CONTACTS)

**Auxiliary Fire Output (AUX):** Changes over in any fire condition, and be used for driving local fire fighting equipment such as sprinkler systems, magnetic door holders, air conditioning shut off, etc.

**Fault Output (FAULT):** This Output is energised in the quiescent condition. In a fault condition, the output relay turns off, to ensure failsafe operation even in the event of total power loss. That is, the normally open contact will be closed when there is no fault, and open when there is a fault. This should be taken into account when any device is connected to the fault relay.

*Typical auxiliary output wiring*

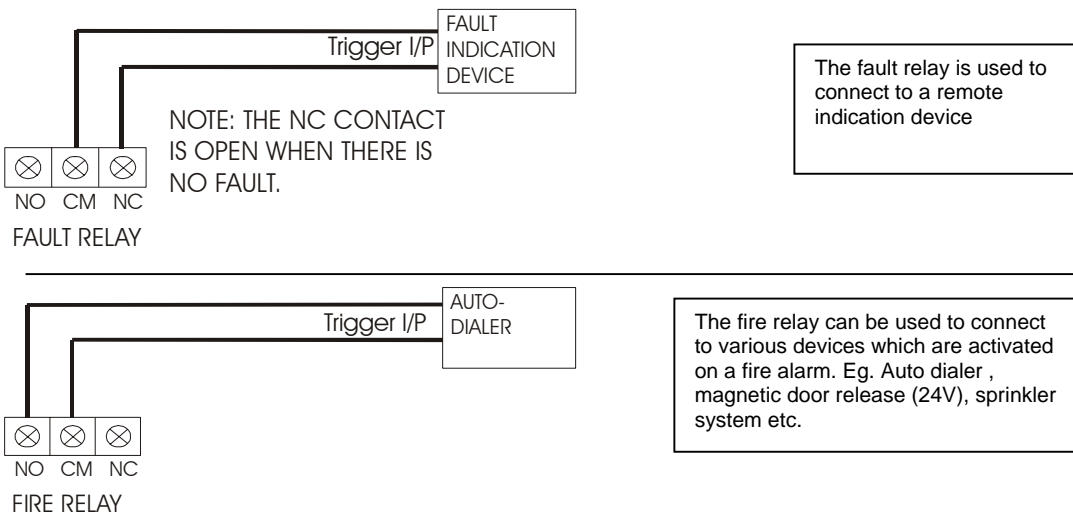

The termination for the above inputs must be as indicated on the main PCB (See page 15). The Earthing of the cable screens should be as shown on page 9.

## 5. MOUNTING THE FIRE ALARM PANEL

It is recommended that the panels door be removed to avoid accidental damage. Also, the termination PCB could be removed and stored in a safe place, while fixing the back box to the wall.

### 5.1 PLANNING CABLE ENTRY

Fig.2 below shows the location of the cable entries to facilitate planning of wiring (home runs) to be brought to the panel.

The grommets can be easily removed by a push from inside the control panel box.

If a grommet is removed, fill the hole with a brass cable gland. If any knockout is removed, but subsequently not used, it should be covered up.

The 230Va.c. Mains cable must be fed into the enclosure via one of the cable entries at the top right corner of the back box. (Refer to "Connecting the Mains" on Page 8).

### 5.2 FIXING THE BACK BOX TO THE WALL

*Figure 2: Plan view inside the enclosure without PCBs. Side view for surface installation.*

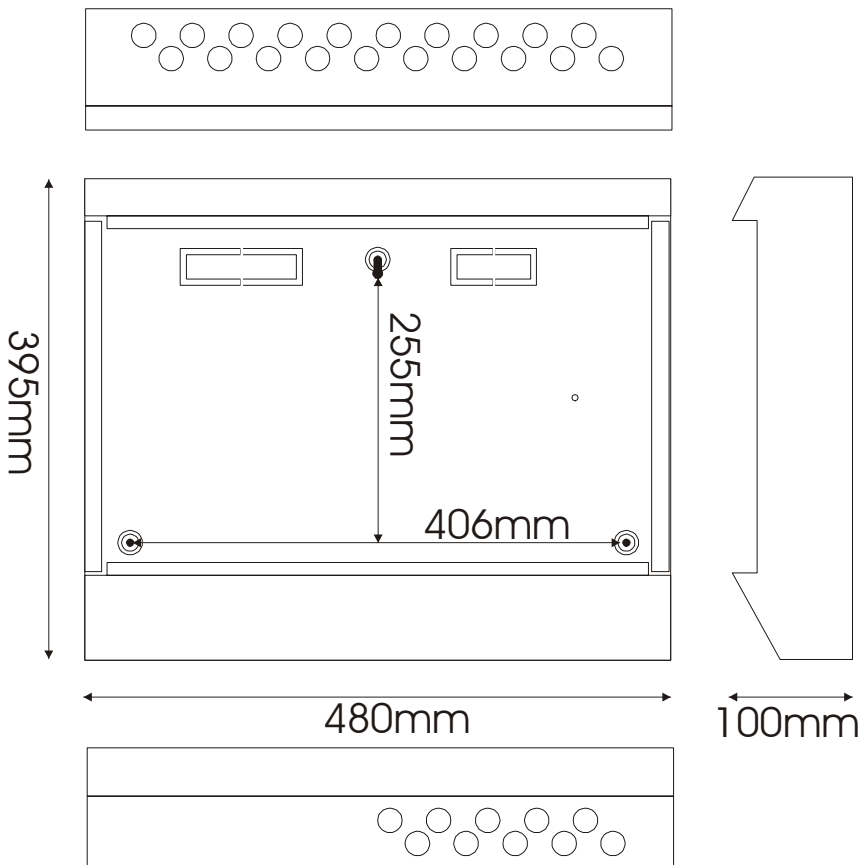

Fix the enclosure to the wall using the three mounting holes provided.

Check the build & condition of the wall to decide a suitable screw fixing.

The mounting holes are designed for No 8 roundhead or countersunk woodscrews (or similar).

Remove any debris from the enclosure.

Take care not to damage the FACP during installation.

## 6 CONNECTING MAINS & BATTERY POWER

### 6.1 CONNECTING THE MAINS POWER

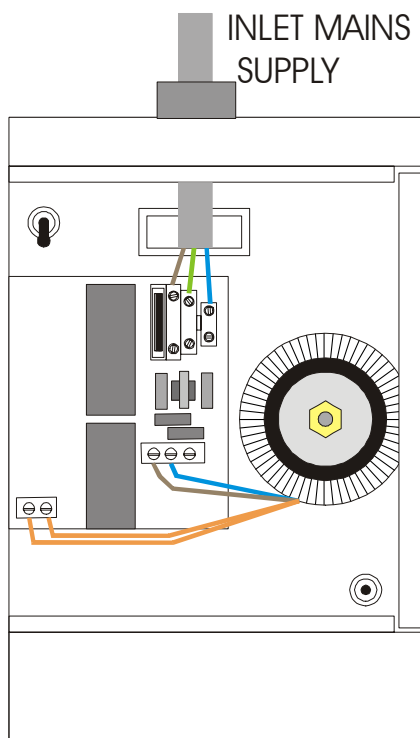

Figure 3: Power Supply PCB layout and Mains connection details

The panel should be connected to 220-240V AC by a 3A rated spur to the fuse box with 1mm<sup>2</sup> to 2.5mm<sup>2</sup> 3-core cable. Nothing else should be connected to this supply. The cable should be fire resistant

The Live, Earth and Neutral connections are marked on the PCB. The Mains is protected by a quick blow 20mm 2A HBC fuse. (Also known as HRC)

The incoming mains cable should be kept separate from the zone cables to help minimise mains interference.

Once the mains is connected, the protective cover should be replaced BEFORE turning on the mains power. This will minimise the chance of electric shock from the PCB.

**MAKE SURE ANY SPARE ENTRY HOLES ARE COVERED WITH THE PLASTIC GROMMETS PROVIDED**

It is advisable to apply power to the panel before connecting any devices, to check for correct operation, and to familiarise yourself with the fire alarm panels controls.

### 6.2 CONNECTING THE BATTERIES

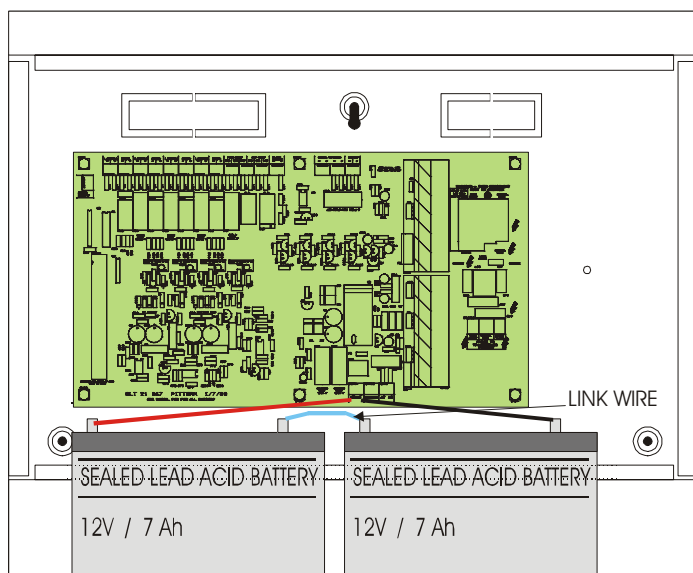

Figure 4: Battery location and connection details

Although there are many sizes of suitable battery, the sizes we usually recommend for the Premier AD are 12V 7Ah,

To calculate the exact requirement, use the equation in section 10, BATTERY CONNECTIONS

The two batteries are wired in **series**.

The **+ve** of one battery is connected to the **red** battery lead.

The **-ve** of the other battery is connected to the **black** battery lead.

The **-ve** of the first battery is connected to the **+ve** of the second battery using the link wire supplied.

**When fitting the batteries, take care not to damage the temperature monitoring thermistors. See figure 4a overleaf.**

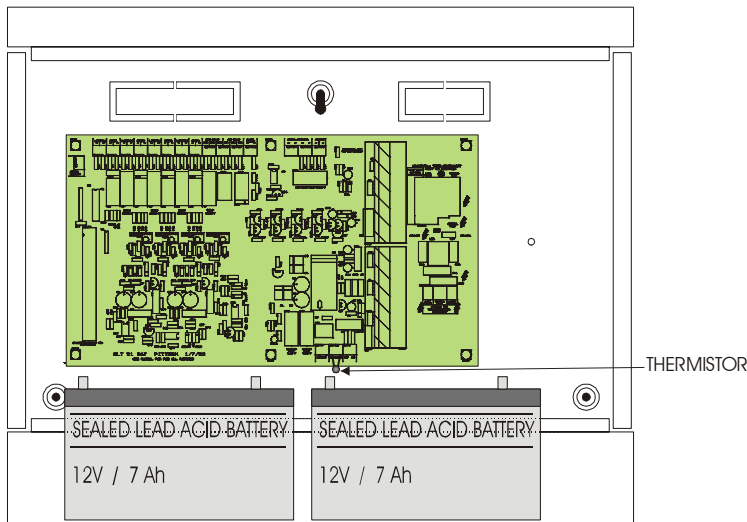

Figure 4a: Thermistor location

The thermistor is used to prevent overcharging the batteries in high ambient temperatures.

## 7. FIELD DEVICE TERMINATION

### 7.1 TERMINATING THE ADDRESSABLE LOOPS AND ALARM (SOUNDER) CIRCUITS.

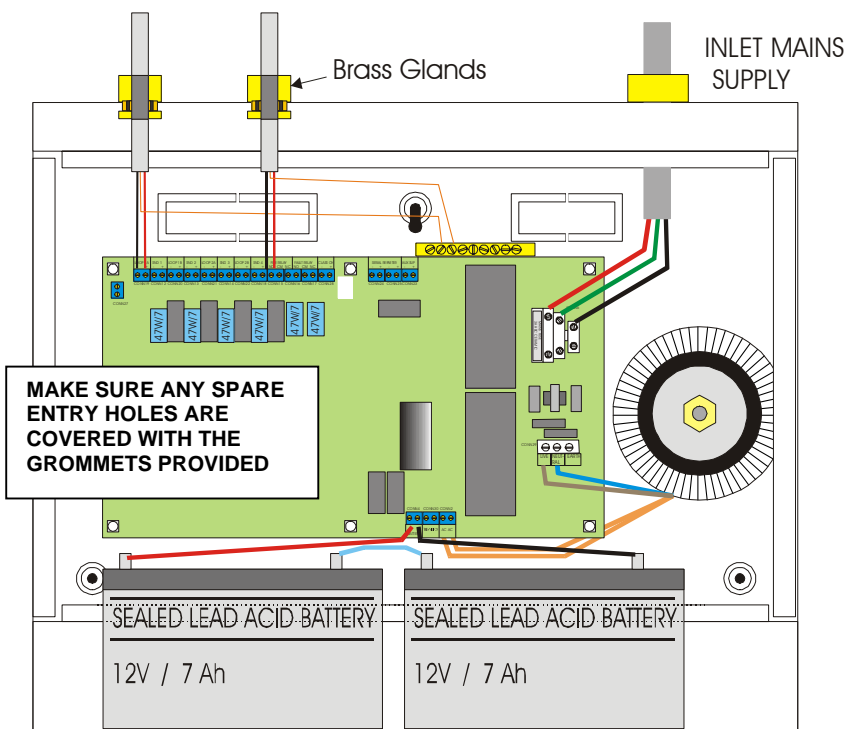

Figure 6: Detector and Sounder Circuit Connection

All cables entering the enclosure should have brass cable glands, which will ensure a good ground to the steel EMC cable grounding plate.

The Detector and Sounder circuits should be connected to the appropriate connector block on the Termination PCB as shown in Figure 6 below.

All screens should be terminated at the brass earthing strip as shown in Figure 6

(For detailed detector and alarm circuit wiring diagrams, please refer to pages 4 and 5.)

### 7.2 AUXILIARY INPUT AND OUTPUT TERMINATIONS

Connect auxiliary input and output cables to the appropriate connector block terminals on the Termination PCB (See Page 15). Screened cables should be terminated as per figure 6.

For a full description of the inputs and outputs available on the Premier AD range of Fire Panels, including typical wiring diagrams please refer to pages 5 & 6.

## 8. DESIGNING THE SYSTEM & CONFIGURING THE FACP

Configuring the premier AD is a fairly straightforward matter. It just takes a bit of thought to zone allocation during the system design stage.

1. Decide on the zone allocation for the system. Each zone can have a maximum of 16 devices fitted. Consider the simplified 3-storey building below.

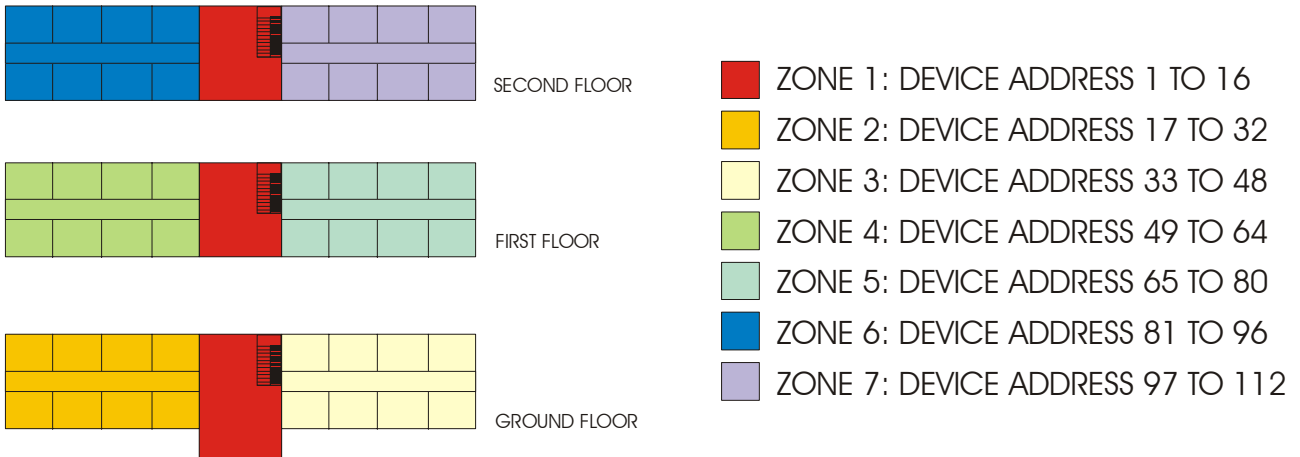

2. If loop controlled sounders are to be used, decide if they should operate zonally, or common. If zonal operation is required, then they should have addresses within the zone that contains the detectors that will activate them. If the loop sounders are to be common, then they should be addressed within a zone that contains only output devices. (In the example above, zone 8 could be used for common loop sounders: address 113 to 126, which allows 14 devices)

**Note:** The cabling can be the same whatever method is used. The devices DO NOT have to be numbered sequentially on the loop. It can be changed from one method to the other, provided there are free addresses to change the sounder’s zones.

3 After the system has been installed, and the cabling checked and the addresses of each device set, connect the loops to the fire alarm panel and power up the system (mains & batteries). It should say “system normal, and only the green Power LED will be lit. There will be the letter “B” in the bottom left hand corner. This stands for Benign, or controls OFF.

```

Fire Alarm Panel
To EN54 pt2 & pt4
System Normal
B
    
```

4. Turn the keyswitch to the Controls Enabled Position. The Letter “B” will now change to an “A”, for controls Active.

```

Fire Alarm Panel
To EN54 pt2 & pt4
System Normal
A
    
```

5. Enter the access code 3 6 9. This will take you to the configuration menu. In this Menu there are options to view loop contents, configure the panel, edit the device message, or view the status of each device. The Covered option will exit from the menu, and return the panel to normal operation.

```

Configuration Menu
1:Lp1 Dev 4:Messages
2:Lp2 Dev 5:Dev Stat
3:Config 6:Covered
    
```

6. Select Option 3 (Configure). The panel will say Configuration in progress please wait. This takes around 20 seconds.

```
Configuration in
Progress

Please Wait
```

7. To check that the panel has read all the devices on loop 1, select option 1 Lp1 Dev. If the loop contents are as expected, go to point 8, otherwise go to Loop Contents Fault Finding on page 16.

```
CO 00|SCC 14|Loop 1
I/O 01|ION 00|DAD 00
ZMU 00|OPT 45|Cancel
HET 03|BGU 05|= Exit
```

8. Select cancel to leave this menu & select option 2 (Lp2 Dev). If the loop contents are as expected, go to point 9, otherwise go to Loop Contents Fault Finding on page 16.

```
CO 00|SCC 14|Loop 2
I/O 01|ION 00|DAD 00
ZMU 00|OPT 45|Cancel
HET 03|BGU 05|= Exit
```

9. Press cancel to leave the menu. The panel is now configured, and will function as a basic system, (press 6 for covered), but it is more useful to enter device labels, to give a more precise location of an alarm device. We recommend that the device labels be entered to allow the panel to be more user friendly during normal operation.

10. Select option 4 for message editing. The panel will now ask for its write enable switch to be set to the on position . (This is the dip switch on the CPU board, switch 1).

```
Please Set The
Write Enable Switch
To the On Position
```

11. The panel will now ask for the loop number, and the loop address of device name to be entered. Press enter to confirm loop 1, and enter again to confirm address 001. Enter the device label using the built in keyboard. The label can be 20 characters long, so try to be as descriptive as possible. Use the caps lock for capital letters. The delete button is used to correct mistakes. When the label has been entered, record the device type & label in the system setup chart in the user manual. Press enter 3 times to move to the next device (or enter the loop number and address to move forward several places.

```
Message Editing
Loop:1 Address:001
Floor 1. Bedroom 20
Can: Exit Ent: Next
```

12 when all devices have been entered, press Cancel to exit the message editing screen. The panel will ask for the write enable switch to be set back to the off position .

```
Please Set The
Write Enable Switch
To the Off Position
```

**NOTE: IF THE PANEL IS POWERED DOWN WITH THE WRITE ENABLE SWITCH ON, IT WILL ERASE THE DEVICE LABELS WHEN IT IS RE-POWERED.**

The panel is now configured and ready for operation.

### 8.1 LOOP CONTENTS FAULT FINDING

If the loop contents are different to what was expected, then there may be some wrong connections to devices (they are polarity sensitive), or double addresses on the loop. (A double address is when 2 or more devices have been set to the same address, so they both answer at the same time.) **If a panel detects a double address, it will light the LEDs of the devices with the problem. (NOTE: only detectors will light their LED. Call points, sounders & interface modules will not be indicated)**

```
Device Type: HEAT *
Value:26  No Devs:1
=====
Loop:1    Address:001
```

Return to the configuration menu & select option 5 (Dev status). Wait for the panel to read loop 1 address 001. (If loop 2 is needed, press 2,enter,001,enter).

The panel will give the device type & its analogue value. If the device is configured, there will be an asterisk (\*) next to the device type. Number of devices should read 1 (a reading of 2 or more will mean a double address is present).

Press next to move to the next address on the loop. (The Previous button cannot be used in this menu. It can only be used to scroll between multiple faults or alarms.) Read all devices on the loop and compare with what was expected. If one address has 2 devices, and another is "missing", the missing device could have a wrong address setting. If many devices are missing, check that they have power. There may be more than one break in the cable (the panel read all devices when it has a single break, and will report a loop fault after a minute or so).

### 8.2 ADDRESS - ZONE TABLE

On the Premier AD, each available address corresponds to a zone, with 1-16 being in zone 1, 17-32 being in zone 2, 33-48 in zone3 etc.

The table below shows the dip switch settings for each address, and the zone that address will be in.

Eg to set address 37, find 37 in the table. It is at sw 7,6,5 = 010, and sw 4,3,2,1= 0101

Remembering that 0 = ON & 1 = OFF, the switch settings for 37 are:

7=ON, 6=OFF, 5=ON, 4=ON, 3=OFF, 2=ON, 1=OFF

		SW 4,3,2,1																LOOP 1	LOOP 2
		0000	0001	0010	0011	0100	0101	0110	0111	1000	1001	1010	1011	1100	1101	1110	1111	LOOP 1	LOOP 2
SW 7,6,5	000	N/A	1	2	3	4	5	6	7	8	9	10	11	12	13	14	15	ZONE 1	ZONE 9
	001	16	17	18	19	20	21	22	23	24	25	26	27	28	29	30	31	ZONE 2	ZONE 10
	010	32	33	34	35	36	37	38	39	40	41	42	43	44	45	46	47	ZONE 3	ZONE 11
	011	48	49	50	51	52	53	54	55	56	57	58	59	60	61	62	63	ZONE 4	ZONE 12
	100	64	65	66	67	68	69	70	71	72	73	74	75	76	77	78	79	ZONE 5	ZONE 13
	101	80	81	82	83	84	85	86	87	88	89	90	91	92	93	94	95	ZONE 6	ZONE 14
	110	96	97	98	99	100	101	102	103	104	105	106	107	108	109	110	111	ZONE 7	ZONE 15
	111	112	113	114	115	116	117	118	119	120	121	122	123	124	125	126	N/A	ZONE 8	ZONE 16

As an alternative to using this chart, use the table on the following page:-



ADDRESS		SWITCHES							ADDRESS		SWITCHES							ADDRESS		SWITCHES							ADDRESS		SWITCHES																											
		1	2	3	4	5	6	7			1	2	3	4	5	6	7			1	2	3	4	5	6	7			1	2	3	4	5	6	7			1	2	3	4	5	6	7												
0=	n	o	t	u	s	e	d		32=	o	n	o	n	o	n	o	n	o	o	64=	o	n	o	n	o	n	o	n	o	o	96=	o	n	o	n	o	n	o	n	o	o	o	o	o	o											
1=	o	f	f	o	n	o	n	o	33=	o	f	o	n	o	n	o	n	o	65=	o	f	o	n	o	n	o	n	o	n	o	97=	o	f	o	n	o	n	o	n	o	o	o	o	o	o	o										
2=	o	n	o	f	f	o	n	o	34=	o	n	o	f	o	n	o	n	o	66=	o	n	o	f	o	n	o	n	o	n	o	98=	o	n	o	f	o	n	o	n	o	o	o	o	o	o	o	o									
3=	o	f	f	o	n	o	n	o	35=	o	f	f	o	n	o	n	o	n	67=	o	f	f	o	n	o	n	o	n	o	99=	o	f	f	o	n	o	n	o	o	o	o	o	o	o	o	o	o									
4=	o	n	o	n	o	f	f	o	36=	o	n	o	n	o	f	o	n	o	68=	o	n	o	n	o	f	o	n	o	n	100=	o	n	o	n	o	f	o	n	o	o	o	o	o	o	o	o	o	o								
5=	o	f	f	o	n	o	n	o	37=	o	f	o	n	o	f	o	n	o	69=	o	f	o	n	o	f	o	n	o	n	101=	o	f	o	n	o	f	o	n	o	o	o	o	o	o	o	o	o	o	o							
6=	o	n	o	f	f	o	n	o	38=	o	n	o	f	f	o	n	o	n	70=	o	n	o	f	f	o	n	o	n	o	102=	o	n	o	f	f	o	n	o	o	o	o	o	o	o	o	o	o	o	o							
7=	o	f	f	o	n	o	n	o	39=	o	f	f	o	n	o	n	o	n	71=	o	f	f	o	n	o	n	o	n	o	103=	o	f	f	o	n	o	o	o	o	o	o	o	o	o	o	o	o	o	o	o						
8=	o	n	o	n	o	n	o	o	40=	o	n	o	n	o	n	o	f	o	n	72=	o	n	o	n	o	n	o	f	o	104=	o	n	o	n	o	f	o	n	o	o	o	o	o	o	o	o	o	o	o	o	o					
9=	o	f	f	o	n	o	n	o	41=	o	f	o	n	o	n	o	f	o	n	73=	o	f	o	n	o	n	o	f	o	105=	o	f	o	n	o	n	o	f	o	o	o	o	o	o	o	o	o	o	o	o	o					
10=	o	n	o	n	o	n	o	o	42=	o	n	o	n	o	n	o	f	o	n	74=	o	n	o	n	o	n	o	f	o	106=	o	n	o	n	o	f	o	n	o	o	o	o	o	o	o	o	o	o	o	o	o					
11=	o	f	f	o	n	o	n	o	43=	o	f	f	o	n	o	n	o	n	75=	o	f	f	o	n	o	n	o	f	o	107=	o	f	f	o	n	o	f	o	o	o	o	o	o	o	o	o	o	o	o	o	o					
12=	o	n	o	n	o	n	o	o	44=	o	n	o	n	o	n	o	f	o	n	76=	o	n	o	n	o	n	o	f	o	108=	o	n	o	n	o	f	o	n	o	o	o	o	o	o	o	o	o	o	o	o	o	o				
13=	o	f	f	o	n	o	n	o	45=	o	f	o	n	o	n	o	f	o	n	77=	o	f	o	n	o	n	o	f	o	109=	o	f	o	n	o	f	f	o	n	o	o	o	o	o	o	o	o	o	o	o	o	o	o			
14=	o	n	o	n	o	n	o	o	46=	o	n	o	n	o	n	o	f	o	n	78=	o	n	o	n	o	n	o	f	o	110=	o	n	o	n	o	f	o	n	o	o	o	o	o	o	o	o	o	o	o	o	o	o	o			
15=	o	f	f	o	n	o	n	o	47=	o	f	f	o	n	o	n	o	n	79=	o	f	f	o	n	o	n	o	f	o	111=	o	f	f	o	n	o	f	o	o	o	o	o	o	o	o	o	o	o	o	o	o	o	o			
16=	o	n	o	n	o	n	o	o	48=	o	n	o	n	o	n	o	f	o	n	80=	o	n	o	n	o	n	o	f	o	112=	o	n	o	n	o	n	o	n	o	f	o	o	o	o	o	o	o	o	o	o	o	o	o			
17=	o	f	f	o	n	o	n	o	49=	o	f	o	n	o	n	o	f	o	n	81=	o	f	o	n	o	n	o	f	o	113=	o	f	o	n	o	n	o	n	o	f	o	o	o	o	o	o	o	o	o	o	o	o	o	o		
18=	o	n	o	n	o	n	o	o	50=	o	n	o	n	o	n	o	f	o	n	82=	o	n	o	n	o	n	o	f	o	114=	o	n	o	n	o	n	o	n	o	f	o	o	o	o	o	o	o	o	o	o	o	o	o	o		
19=	o	f	f	o	n	o	n	o	51=	o	f	f	o	n	o	n	o	f	o	83=	o	f	f	o	n	o	n	o	f	o	115=	o	f	f	o	n	o	n	o	n	o	f	o	o	o	o	o	o	o	o	o	o	o	o		
20=	o	n	o	n	o	n	o	o	52=	o	n	o	n	o	n	o	f	o	n	84=	o	n	o	n	o	n	o	f	o	116=	o	n	o	n	o	n	o	n	o	f	o	o	o	o	o	o	o	o	o	o	o	o	o	o		
21=	o	f	f	o	n	o	n	o	53=	o	f	o	n	o	n	o	f	o	n	85=	o	f	o	n	o	n	o	f	o	117=	o	f	o	n	o	n	o	n	o	f	o	o	o	o	o	o	o	o	o	o	o	o	o	o	o	
22=	o	n	o	n	o	n	o	o	54=	o	n	o	n	o	n	o	f	o	n	86=	o	n	o	n	o	n	o	f	o	118=	o	n	o	n	o	n	o	n	o	f	o	o	o	o	o	o	o	o	o	o	o	o	o	o	o	
23=	o	f	f	o	n	o	n	o	55=	o	f	f	o	n	o	n	o	f	o	87=	o	f	f	o	n	o	n	o	f	o	119=	o	f	f	o	n	o	n	o	n	o	f	o	o	o	o	o	o	o	o	o	o	o	o	o	o
24=	o	n	o	n	o	n	o	o	56=	o	n	o	n	o	n	o	f	o	n	88=	o	n	o	n	o	n	o	f	o	120=	o	n	o	n	o	n	o	n	o	f	o	o	o	o	o	o	o	o	o	o	o	o	o	o	o	
25=	o	f	f	o	n	o	n	o	57=	o	f	o	n	o	n	o	f	o	n	89=	o	f	o	n	o	n	o	f	o	121=	o	f	o	n	o	n	o	n	o	f	o	o	o	o	o	o	o	o	o	o	o	o	o	o	o	
26=	o	n	o	n	o	n	o	o	58=	o	n	o	n	o	n	o	f	o	n	90=	o	n	o	n	o	n	o	f	o	122=	o	n	o	n	o	n	o	n	o	f	o	o	o	o	o	o	o	o	o	o	o	o	o	o	o	
27=	o	f	f	o	n	o	n	o	59=	o	f	f	o	n	o	n	o	f	o	91=	o	f	f	o	n	o	n	o	f	o	123=	o	f	f	o	n	o	n	o	n	o	f	o	o	o	o	o	o	o	o	o	o	o	o	o	o
28=	o	n	o	n	o	n	o	o	60=	o	n	o	n	o	n	o	f	o	n	92=	o	n	o	n	o	n	o	f	o	124=	o	n	o	n	o	n	o	n	o	f	o	o	o	o	o	o	o	o	o	o	o	o	o	o	o	
29=	o	f	f	o	n	o	n	o	61=	o	f	o	n	o	n	o	f	o	n	93=	o	f	o	n	o	n	o	f	o	125=	o	f	o	n	o	n	o	n	o	f	o	o	o	o	o	o	o	o	o	o	o	o	o	o	o	
30=	o	n	o	n	o	n	o	o	62=	o	n	o	n	o	n	o	f	o	n	94=	o	n	o	n	o	n	o	f	o	126=	o	n	o	n	o	n	o	n	o	f	o	o	o	o	o	o	o	o	o	o	o	o	o	o		
31=	o	f	f	o	n	o	n	o	63=	o	f	f	o	n	o	n	o	f	o	95=	o	f	f	o	n	o	n	o	f	o	127=	n	o	t	u	s	e	d																		

## 9. ZONE DISABLEMENT

The Premier AD is designed to operate as a zone based panel. You can therefore only disable a whole zone. It is not possible to disable individual devices.

### 9.1 WHY USE ZONE DISABLEMENT

To aid commissioning and assist routine maintenance checks, any of the zones or the sounder circuits can be disabled.

When a zone (or sounder cct) is disabled, the panel will not respond to any fault or fire signals it receives from that zone\*. This might be used if the system requires routine maintenance, and the customer needs the system to continue running, but doesn't want spurious false alarms.

The panel will respond in the usual manner to any events in any non-disabled zones.

**The premier AD allows the 4 conventional sounder circuits to be disabled individually, and also allows the loop powered sounders to be disabled**

### 9.2 TO PROGRAMME ZONE (OR SOUNDERS) AS DISABLED

Any number of zones (or the sounders) can be disabled, but it is good practice to only disable one zone at a time.

1. Insert and turn control key to enabled position;
2. Press DISABLE button and the ZONE 1 DISABLED LED will flash (The panel is now in SELECT DISABLEMENT MODE)
3. Press DISABLEMENT SELECT until the required zone or sounder circuit is lit. Press DISABLEMENT CONFIRM button, and the LED will come on steady, along with the GENERAL DISABLEMENT LED This section is now disabled\*.
4. If more than one zone (or sounder) needs to be disabled, then press DISABLEMENT SELECT again until the required zone (or sounder) is selected.
5. If the panel needs to be taken out of SELECT DISABLEMENT MODE (eg to silence a fault on another part of the system), turn the keyswitch off, then back on again.
6. Once all the work has been done the zones need to be enabled again. If the panel is still in SELECT DISABLEMENT MODE, jump to paragraph 7, otherwise, turn the keyswitch to controls enabled, press DISABLE button. The panel is now in SELECT DISABLEMENT MODE
7. Press the DISABLEMENT SELECT button until the disabled zone has been selected. Press DISABLEMENT CONFIRM button to de-select disablement. Scroll to any other disabled zone and enable in the same way. When all zones are enabled again, the GENERAL DISABLEMENT LED will turn off. Turn the keyswitch to off position to return the system to normal.

**\*To enable the system to be functional in the event of a real fire during maintenance, the manual call points remain active, even if the zone they are in has been disabled**

## 10. TEST MODE

### 10.1 WHY USE TEST MODE

To aid commissioning and assist routine maintenance check, a non-latching 'one man test' facility is available.

When a detector or manual call point is triggered on any zone in Test, the Alarm sounders operate for approximately eight seconds on and four seconds off. This cycle continues until the cause of the Alarm is removed (either by the test smoke clearing from the detector or the manual call point being reset), sounders will then stop activating.

Should an Alarm occur on a zone that is not programmed to test, the Fire Alarm Panel will cancel the test mode. After the cause of the alarm has been checked, and the panel reset, test mode will have to be selected again to resume testing.

### 10.2 TO PROGRAMME ZONE IN TEST MODE

NOTE: Only **one zone** can be programmed in test at any one time.

1. Insert and turn control key to enabled position;
2. Press TEST Button, followed by the code **2 4 8**.
3. The GENERAL TEST LED will light steady, and Zone 1 test led will flash.
4. Press TEST FUNCTION SELECT button to select the zone to be tested.
5. Press confirm to enter test mode for this function. The LED will now be steady.
6. Once testing of that zone is completed, press TEST FUNCTION SELECT button to move to another Zone or turn the control key switch to off position to exit test mode.

**NOTE: If testing a call point, it will trigger the panel into alarm immediately, but it will need to stay active for around 8 seconds before the panel registers it as a test mode alarm. If the call point is active for less than 8 seconds, the sounders WILL NOT RESET.**

### 8.3 TO PROGRAM SOUNDER CIRCUITS IN TEST MODE

NOTE: Only **one sounder circuit or the loop sounders** can be programmed in test mode at any one time.

**NOTE: Only the ADDRESSABLE SOUNDERS can be tested with the loop sounder one man test mode. The ASSOCIATED SOUNDER BASES cannot be tested this way because of their slow stop/start time.**

1. Insert and turn control key to enabled position;
2. Press TEST Button, followed by the code 2 4 8.
3. Zone 1 test led will flash.
4. Press TEST FUNCTION SELECT button to select the sounder to be tested.
5. Press confirm to enter test mode for this function. The LED will now be steady.
6. The Sounders will now pulse 3 seconds on, 3 seconds off until they are taken out of test mode. This allows all the sounders to be tested for correct operation, and dB output.
7. Once testing of that sounder circuit is completed, press TEST FUNCTION SELECT button to move to another circuit, or turn the control key switch to off position to exit test mode

To test associated sounder bases, use the stop/start sounder button (evacuate). Note that the sounders will take up to 9 seconds to start.

\*\*\*NOTE\*\*\*

Associated sounder bases are controlled by the detector. **Removing the detector will leave the sounder base inoperative.**

## 11. GENERAL FAULT FINDING

### 11.1 COMMON FAULT.

This is a general indicator which lights whenever a fault is present. It doesn't refer to a specific fault.

### 11.2 ZONE FAULTS

There are several reasons for the zone fault LED to light.

1. There is a break, or short circuit to devices in that zone,
2. A device has been removed from that zone
3. A device in that zone is communicating a fault condition to the panel with its analogue value. A value less than 8 is usually a fault condition. (This could be a zone monitor reporting a fault in its external PSU for example.)

The LCD screen should give further information about the fault. It may give the loop, address & label of the device causing a problem. If it reports a loop fault, then this indicates a break (or short) in the loop cable. (note that if Spurs are used, the panel may not detect the brake, but will still report the device missing)

```
[01] *** FAULT ***
=====
Lp:1 Ad:001 Zn:01
```

Entering the device status menu & viewing the address which shows a fault will also help identify the problem. If the device is present, but gives a fault value (less than 8), then there is a problem with that device or one of its add on components (eg power supply)

```
Device Type: ZMU *
Value:04 No Devs:1
=====
Loop:1 Address:001
```

If the device is missing (NONE\*), then :-

- Check the device has not been removed
- Check that there is power to the base
- Check that its address hasn't been changed (compare to system set-up chart)
- Check that the base contacts are clean and free from dirt & corrosion
- If possible, try a replacement head (remembering to set the correct address)

### 11.3 SUPPLY FAULTS

- a. BATTERY FAULT
  - Loss of Battery power – Remedy
  - i. Check battery fuse FS2.
  - ii. Check that battery connections are secure.
- b. CHARGER FAULT
  - Loss of Mains power – Remedy
  - i. Check mains fuse (Conn 6).
  - ii. Check that main power is present.
  - iii. Check charger fuse FS1.
- c. LOW BATTERY
  - Low Battery voltage detected – Remedy
  - i. Check battery voltage. (should be around 26-27V)
  - ii. Check that 2 x 12v batteries are connected in SERIES) to give 24V
  - iii. Check that charger fuse FS1 is ok

```
*** FAULT ***

Charger or Battery
```

Other possible causes of supply faults are:-

#### Wrong Charging Voltage.

The charging voltage should be 28.3V off load at 22-24°C. If it has been altered, reset using potentiometer VR1

#### Overcharged Batteries.

Remove the batteries and measure the voltage. If it is reading over 27.4 then the batteries are overcharged. Try to run the panel on batteries only for half an hour or so to try to discharge the batteries. If this doesn't solve the problem, replacement batteries will be required.

## 11.4 EARTH FAULTS

An EARTH fault indicates that something is shorting to earth (usually through the cable screen). Disconnect the earth screens one at a time to determine the problem line.

(Note: connecting other equipment , eg an oscilloscope , to the panel can give an earth fault)

The voltage between battery –Ve and earth should be **14-16** volts. If it is not, the voltage should indicate what is shorting to earth.

**\*\*\*DO NOT DISCONNECT THE MAINS EARTH CONNECTION. THIS WILL CAUSE A PROBLEM WITH THE PANELS OPERATION\*\*\***

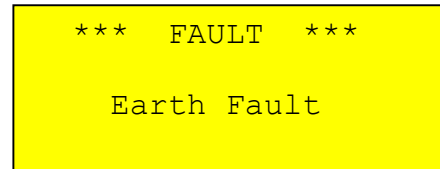

## 11.5 DOUBLE ADDRESS

This indicates that a double address has been detected. This usually happens if a head is replaced during maintenance, and its address has been wrongly set. The panel will report 2 fault addresses, one will be the double address, and the other will be a missing device. As a further aid to finding the fault, the panel will light the LEDs of any detectors with a double address (Call points, Sounders & I/O units will not be indicated as they have no panel controlled LED to light up)

## 11.6 SYSTEM FAULT

A system fault is an abnormal microprocessor running condition due to various unexpected phenomena

This will result in the panel attempting to correct itself. Should this fault occur, the System Fault LED, General Fault LED, General Fault relay and fault internal buzzer will be constantly active until the control keyswitch is turned from off position to control enable position. This should cause this fault condition to reset. If not, consult your supplier.

\*\*Note that the system fault LED will Light if the Write enable switch is left on after entering a device message. This is to warn of the risk of erasing the stored data. Use the keyswitch to reset after the switch has been turned off.

## 11.7 PRE-ALARM

**This is not a fault condition. The panel has detected a high reading from one of the devices on the loop. This could be caused by a fire starting (in which case it acts as an early warning), or it could be caused by a contaminated head. The panel will report the location of the problem device, which should then be investigated.**

## 11.8 SOUNDER FAULTS

On the premier AD there are separate fault indications for each sounder circuit, and a separate one for the loop sounders.

Conventional sounders:

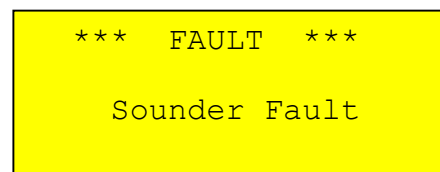

The fault LED will flash for an open circuit fault, and will be steady for a short circuit fault.

Check that the correct END of Line resistor has been fitted. (10K – brown, black, orange, gold)

Check that all sounder fuses are OK (FS4, FS5, FS6 & FS7 – 250mA TD)

If working on an existing installation, check that the devices are **polarised**. (See Page 5)

Check cable continuity (remove from panel and measure continuity. Should read 10K)

Loop controlled sounders:

If sounder circuit controllers are used, check as per conventional sounder, and also check its power supply.

For loop powered sounders, check that all sounders are communicating, and check their analogue value. If a sounder is returning a value less than 8, then it has detected an internal fault and should be replaced.

If they are not communicating, then check that they have power, and that the power is connected the correct way. If they have power, they may be damaged. Try a replacement if available.

## 11.9 LOOP WIRING FAULTS

A loop fault can be caused by a break, or short circuit in the Loop wiring. Open the panel and look for the 4 green LEDs on the termination PCB. Under normal conditions these should be all lit steady. The LEDs represent Loop1 Side A, Loop 1 side B, Loop2 Side A and Loop 2 side B.

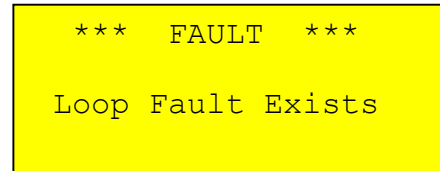

If both loop LEDs for either loop are off, then this indicates that there is a short on the loop that the isolators couldn't bypass. (Check that the isolators are enabled, and aren't set for a cable continuity check). Split the loop half way, and check if either side of the loop will power up. Continue making more splits until the short has been found.

If The LEDs for a loop are flashing (both on, side a only, both on, side b only etc), then this indicated a break in the wiring. This could be caused by either a break, or a pair of isolators shutting down a short circuit. If there are several missing devices (wait for the zone fault LED & check the addresses in that zone), then there is probably a short circuit on the loop (look for isolators lit Yellow or flashing). The missing devices should give an indication of the section with the break. Investigate that section as per the dead short circuit fault tracking method, as described above.

If there are no missing devices, then there is probably a simple break. Disconnect one side of the loop and check which devices can be read. The break should be after the last read device.

## 12. STANDBY BATTERY REQUIREMENTS

The Following Table shows the Quiescent, Fault & alarm currents of the main parts of a Premier AD Fire Alarm System

Device	Product Code	I <sub>q</sub> (mA)	I <sub>fit</sub> (mA)	I <sub>alm</sub> (mA)	Max per Loop	Max per System
PREMIER AD FIRE ALARM CONTROL PANEL	NPAD	150	200	350	N/A	1
PREMIER AD REPEATER PANEL	REP-AD	200	220	220	N/A	1
Fyreye Addressable Ionisation Smoke Detector	FEAI2000	0.6	N/A	2	126	126
Fyreye Addressable Optical Smoke Detector	FEAO2000	0.6	N/A	2	126	126
Fyreye Addressable Heat Detector	FEAH2000	0.6	N/A	2	126	126
Fyreye Addressable High Temperature Heat Detector	FEAHH2000	0.6	N/A	2	126	126
Fyreye Addressable Multi-point Detector	FEAOH2000	0.6	N/A	2	126	126
Fyreye Addressable Carbon Monoxide Detector	FEAHH2000	0.6	N/A	2	126	126
Fyreye Addressable Sounder Base	FEA-SB	0	N/a	3*	126	126
Zeta Addressable Call Point	ZT-MCP/AD	0.4	N/a	13	126	126
Zeta Weatherproof Addressable Call Point	ZT-MCP/AD/WP	0.4	N/a	13	126	126
Zeta Input Unit	ZIU	2	2	10	126	126
Zeta Input Output Unit	ZIOU	2	2	10	16	16
Zeta Sounder Control Module	ZSCC	2	2	10	16	16
Zone Monitor Unit	ZT-ZM	2	2	50	126	126
Fyreye Addressable Beam Detector (5-50m)	ZTA-FR50	t.b.c.	t.b.c.	t.b.c.	t.b.c.	t.b.c.
Fyreye Addressable Beam Detector (50-100m)	ZTA-FR100	t.b.c.	t.b.c.	t.b.c.	t.b.c.	t.b.c.
Fyreye Plus Addressable Aspiration Detector	FE+50/AD	t.b.c.	t.b.c.	t.b.c.	t.b.c.	t.b.c.
Zeta Addressable Maxitone Sounder	ZAMT	1.5	N/a	9	32	32
Zeta Addressable Miditone Sounder	ZAMD	1.5	N/a	9	32	32
Zeta Addressable Securetone Sounder	ZAST	1.5	N/a	9	32	32
Zeta Addressable Remote LED Indicator	ZTA/LE2	1.5	N/a	10	32	32
Zeta Conventional Maxitone Sounder	ZMT/8	0	N/a	15	N/a	N/a
Zeta Conventional Miditone Sounder	ZMD/8	0	N/a	15	N/a	N/a
Zeta Conventional Securetone Sounder	ZST/8	0	N/a	15	N/a	N/a
Zeta Conventional Megatone Sounder	ZIDC	0	N/a	200	N/a	N/a
Zeta Conventional Flasher	ZFL2RR	0	N/a	90	N/a	N/a
Zeta Conventional Sounder Flasher	ZLT/8RR	0	N/a	110	N/a	N/a
Zeta Conventional 6" Bells	ZTB6B/24	0	N/a	25	N/a	N/a
Zeta Conventional 8" Bells	ZTB8B	0	N/a	35	N/a	N/a
Fyreye Conventional Optical Detector	FEO2000	0.06	N/a	25	N/a	N/a
Fyreye Conventional Heat Detector (A1R)	FEHR2000	0.04	N/a	25	N/a	N/a
Fyreye Conventional Heat Detector (CS)	FEFH2000	0.04	N/a	25	N/a	N/a

\* 3 mA Version of sounder base due May 2004. Any supplied before this date will take up to 9 mA.

## 12.1 STANDBY BATTERY CALCULATION

In order to calculate the standby battery size required, the following formula can be used:-

$$\text{Battery Size (Standby time in Amp Hours)} = 1.25 \times [(T_{\text{ALM}} \times I_{\text{ALM}}) + (T_{\text{SBY}} \times (I_{\text{QP}} + I_{\text{QZ}}))]$$

Where:

- $T_{\text{ALM}}$  = Maximum time in hours required for the alarm [ $\frac{1}{2}$  hour is most common time]
- $I_{\text{ALM}}$  = Total Alarm Current in amps for all alarm devices connected to the alarm circuits
- $T_{\text{SBY}}$  = Standby time in hours for the system after mains failure [normally 24, 48 or 72 hr]
- $I_{\text{QP}}$  = Quiescent current in amps of control panel in fault condition [because of mains failure]
- $I_{\text{QZ}}$  = Quiescent current in amps of all detection zones. Eg Ion detector 0.00005 Amp (50  $\mu\text{A}$ ) , Optical Detector = 0.0001 Amp (100  $\mu\text{A}$ )

Typical Example:

A system comprises of 80 Addressable Optical detectors, 80 Sounder bases and the required standby is 24 hours. It will need to operate in alarm for  $\frac{1}{2}$  hour.

Calculate the battery size required.

$$T_{\text{ALM}} = 0.5 \text{ Hr}$$

$$I_{\text{Alm-snd}} = 80 \times 0.003 = 0.24\text{A}$$

$$T_{\text{SBY}} = 24 \text{ Hr}$$

$$I_{\text{QP}} = 0.200\text{A}$$

$$I_{\text{AP}} = 0.350\text{A}$$

$$I_{\text{QZ}} = 80 \times 0.0006 = 0.048\text{A} \text{ [the quiescent current for an Addressable Optical detector is } 600 \mu\text{A}$$

$$I_{\text{alm}} = I_{\text{alm-snd}} + I_{\text{AP}}$$

Therefore using the equation:

$$\text{Battery Size (Standby time in Amp Hours)} = 1.25 \times [(T_{\text{ALM}} \times I_{\text{ALM}}) + (T_{\text{SBY}} \times (I_{\text{QP}} + I_{\text{QZ}}))]$$

$$\text{Battery Size (Standby time in Amp Hours)} = 1.25 \times [(0.5 \times (0.35+0.24)) + (24 \times (0.2 + 0.048))]$$

$$\text{Battery Size (Standby time in Amp Hours)} = 1.25 \times [0.295 + (24 \times 0.248)]$$

$$\text{Battery Size (Standby time in Amp Hours)} = 1.25 \times [0.295 + 5.952]$$

$$\text{Battery Size (Standby time in Amp Hours)} = 1.25 \times 6.247$$

$$\text{Battery Size (Standby time in Amp Hours)} = 7.80 \text{ Amp Hours}$$

This system would require a minimum of 7.80 batteries, so we would recommend using 7Ah batteries.

Note: This calculation is based on the 3mA sounder base.



### 13. PCB TERMINATION CONNECTIONS.

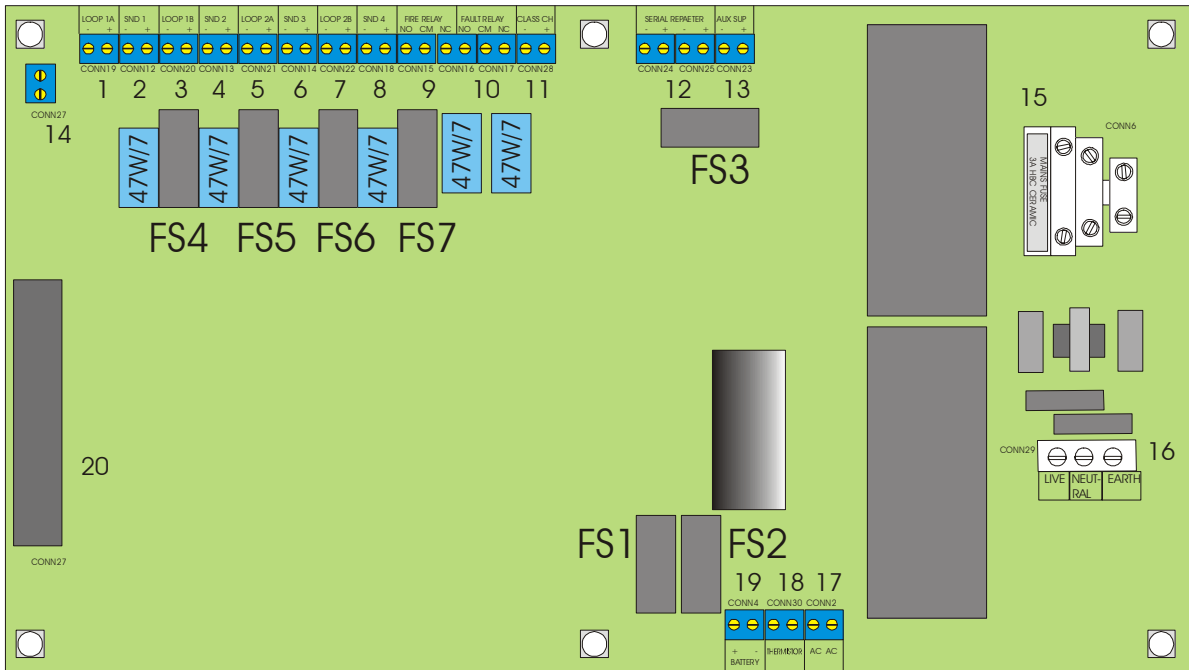

#### 13.1 CONNECTIONS

Connection No	Description	Use
1	LOOP 1A +&-	Connect to loop 1 side A
2	SND 1 +&-	Connect to sounder circuit 1 (sirens/bells)
3	LOOP 1B +&-	Connect to loop 1 side B
4	SND 2 +&-	Connect to sounder circuit 2 (sirens/bells)
5	LOOP 2A +&-	Connect to loop 2 side A
6	SND 3 +&-	Connect to sounder circuit 3 (sirens/bells)
7	LOOP 2B +&-	Connect to loop 2 side B
8	SND 4 +&-	Connect to sounder circuit 4 (sirens/bells)
9	FIRE RELAY NO/CM/NC	Activates on fire (including test mode)
10	FAULT RELAY NO/CM/NC	Normally powered ie NO is closed with no fault
11	CLASS CHANGE	Join terminals to activate sounders
12	SERIAL REPEATER +&-	Connect to RS485 Repeater (2 or 4 cores)
13	AUX SUP +&-	24 volt supply for repeater
14	CONN 27	EARTH connection to display PCB & SCREEN TAG
15	CONN 6	MAINS TERMINAL BLOCK
16	CONN 29	Filtered mains to transformer
17	AC AC	Connected to transformer secondary (30VAC)
18	THERMISTOR	Thermistor to prevent thermal overcharge
19	BATTERY + & -	Connect 2 x 12V SLA batteries in SERIES (ie 24V)
20	CONN 3	50 way ribbon cable to display PCB

#### 13.2 FUSES

FUSE NO	DESCRIPTION	RATING
FS1	Charger Fuse	2.5A time delay 5 x 20mm glass
FS2	Battery Fuse	2.5A time delay 5 x 20mm glass
FS3	Aux Supply	200mA time delay 5 x 20mm glass
FS4	Sounder circuit 1	250mA time delay 5 x 20mm glass
FS5	Sounder circuit 2	250mA time delay 5 x 20mm glass
FS6	Sounder circuit 3	250mA time delay 5 x 20mm glass
FS7	Sounder circuit 4	250mA time delay 5 x 20mm glass
INLET FUSE	Mains Protection Fuse	3.15A Quick Blow HBC 5 x 20mm ceramic

## 14. PANEL SPECIFICATIONS

### 14.1 ENCLOSURE SPECIFICATIONS

DESCRIPTION	VALUE
ENCLOSURE SIZE	480 x 395 x 100 mm
TOP CABLE ENTRIES	20 x 19mm DIA GROMMETED ENTRIES
BOTTOM CABLE ENTRIES	10 x 19mm KNOCKOUT ENTRIES
REAR CABLE ENTRIES	2 SNAP OUTS, 60 x 20mm

### 14.2 ELECTRICAL SPECIFICATIONS

ELECTRICAL DESCRIPTION	VALUE
MAINS VOLTAGE	230V AC +/- 10% @ 50/60 Hz
BATTERY VOLTAGE	24V DC (2 X 12V SLA BATTERY)
SYSTEM VOLTAGE	24V DC NOMINAL (18 – 32 V)
SYSTEM VOLTAGE RIPPLE	2V PK-PK MAX
CHARGER SIZE	UP TO 7AH in 24 Hours
ZONE VOLTAGE	24V DC NOMINAL (+9 volt data)
SOUNDER ALARM OUTPUTS	4 x 250mA @ 24V DC (Nominal)
AUXILIARY FAULT OUTPUT	1 x RELAY SELV (1A MAX)
AUXILIARY FIRE OUTPUT	1 x RELAY SELV (1A MAX)
NUMBER OF LOOPS	2 LOOPS
MAXIMUM NUMBER OF ZONES	16 ZONES
MAXIMUM LOOP CAPACITY	126 DEVICES PER LOOP
MAXIMUM ZONE CAPACITY	16 DEVICES PER ZONE
MAXIMUM LOOP RESISTANCE	25 ohms
MAXIMUM LOOP CAPACITANCE	0.3µF
MAXIMUM VOLTAGE PICKUP ALLOWED	50mV
REMOTE SOUNDER ACTIVATION	VIA N/O CONTACTS
SOUNDER END OF LINE DEVICE	10 K RESISTOR
CHARGER VOLTAGE	28.3V @ 22-24°C (NO BATTERY CONNECTED)
LOOP SHORT CIRCUIT PROTECTION	750mA
CHARGER SHORT CIRCUIT PROTECTION	Batteries less than 20V
TOTAL CHARGER OUTPUT	1.5 Amp